

1951

# Inner-complex compounds of alicyclic vic-dioximes

Roger Conant Voter  
*Iowa State College*

Follow this and additional works at: <https://lib.dr.iastate.edu/rtd>

 Part of the [Analytical Chemistry Commons](#)

## Recommended Citation

Voter, Roger Conant, "Inner-complex compounds of alicyclic vic-dioximes " (1951). *Retrospective Theses and Dissertations*. 14147.  
<https://lib.dr.iastate.edu/rtd/14147>

This Dissertation is brought to you for free and open access by the Iowa State University Capstones, Theses and Dissertations at Iowa State University Digital Repository. It has been accepted for inclusion in Retrospective Theses and Dissertations by an authorized administrator of Iowa State University Digital Repository. For more information, please contact [digirep@iastate.edu](mailto:digirep@iastate.edu).

# NOTE TO USERS

This reproduction is the best copy available.

**UMI**<sup>®</sup>



INNER-COMPLEX COMPOUNDS OF  
ALICYCLIC VIC-DIOXIMES

by

Roger Conant Voter

A Dissertation Submitted to the  
Graduate Faculty in Partial Fulfillment of  
The Requirements for the Degree of  
DOCTOR OF PHILOSOPHY

Major Subject: Analytical Chemistry

**Approved:**

Signature was redacted for privacy.

**In Charge of Major Work**

Signature was redacted for privacy.

**Head of Major Department**

Signature was redacted for privacy.

**Dean of Graduate College**

Iowa State College

1951

UMI Number: DP13029

### INFORMATION TO USERS

The quality of this reproduction is dependent upon the quality of the copy submitted. Broken or indistinct print, colored or poor quality illustrations and photographs, print bleed-through, substandard margins, and improper alignment can adversely affect reproduction.

In the unlikely event that the author did not send a complete manuscript and there are missing pages, these will be noted. Also, if unauthorized copyright material had to be removed, a note will indicate the deletion.

**UMI**<sup>®</sup>

---

UMI Microform DP13029

Copyright 2005 by ProQuest Information and Learning Company.

All rights reserved. This microform edition is protected against unauthorized copying under Title 17, United States Code.

ProQuest Information and Learning Company  
300 North Zeeb Road  
P.O. Box 1346  
Ann Arbor, MI 48106-1346

QD369  
V3412

TABLE OF CONTENTS

	Page
I. INNER-COMPLEX COMPOUNDS OF ALICYCLIC <u>VIC-DIOXIMES</u> . . . . .	1
A. Introduction . . . . .	1
B. Purpose of the Investigation . . . . .	7
II. PART ONE: THE PREPARATION OF SEVERAL ALICYCLIC <u>VIC-DIOXIMES</u> AND THEIR APPLICATIONS TO ANALYTICAL <u>CHEMISTRY</u> . . . . .	9
A. Review of the Literature . . . . .	9
B. Materials and Apparatus . . . . .	20
C. Experimental Methods and Results . . . . .	25
1. 1,2-Cyclopentanedionedioxime . . . . .	26
a. Preparation . . . . .	26
b. A study of some of its properties . . . . .	30
2. 1,2-Cyclohexanedionedioxime . . . . .	32
a. Use as a gravimetric and qualitative reagent for nickel . . . . .	32
b. Use as a gravimetric reagent for palladium . . . . .	34
3. 1,2-Cycloheptanedionedioxime . . . . .	35
a. Preparation . . . . .	35
b. Use as a macro-gravimetric reagent for nickel . . . . .	36
c. Use as a micro-gravimetric reagent for nickel . . . . .	40
d. Use as a gravimetric reagent for palladium . . . . .	45
4. 1,2-Cyclodecanedionedioxime . . . . .	52
a. Preparation . . . . .	52
b. A study of some of its properties . . . . .	56

T9938 J

	Page
D. Conclusions and Summary . . . . .	57
III. PART TWO: INFRARED SPECTROSCOPIC STUDY OF THE NATURE OF THE HYDROGEN BOND IN THE INNER-COMPLEX COMPOUNDS . . . . .	60
A. Review of the Literature . . . . .	60
B. Instruments . . . . .	71
C. Materials . . . . .	72
D. Experimental . . . . .	74
1. Methods . . . . .	75
2. Results . . . . .	76
E. Discussion . . . . .	92
F. Summary . . . . .	100
IV. SUGGESTIONS FOR FUTURE WORK . . . . .	102
V. LITERATURE CITED . . . . .	104
VI. ACKNOWLEDGMENTS . . . . .	110

## I. INNER-COMPLEX COMPOUNDS OF ALICYCLIC VIC-DIOXIMES

The great value of organic reagents as tools in the schema of analytical chemistry has been firmly established in recent decades (21). But their worth has not been limited to practical applications alone. The chemist, in his desire to improve and widen the field of use of these indispensable chemical implements, has been led to further exhaustive study and, consequently, a better understanding of metallo-organic complexes. Both aspects, the fundamental and the applied, have been examined in the researches from which these writings are drawn.

### A. Introduction

Of the organic analytical reagents in common use, very few are better known or more widely used than 2,3-butanedionedioxime (also commonly called dimethylglyoxime or biacetyldioxime). This reagent, relatively selective in its reactions with nickel(II) and palladium(II) ions, has served well as a qualitative, gravimetric and colorimetric reagent. It has been, indeed, the basis for the most important analytical procedures involving these ions.

Diehl has enumerated a list of standards (17, p. 14) which should be met by organic analytical reagents in



order that they may be considered entirely satisfactory for general use in analytical methods. One of these requirements, namely, solubility in water\*, is not met by 2,3-butanedionedioxime, which must be made up in organic solvents (usually ethanol or acetone). Other common but lesser known vic-dioximes suffer from this same disadvantage (96). Whenever an organic reagent must be dissolved in an organic solvent and added to an aqueous solution, there exists the serious danger of contaminating the nickel precipitate with excess reagent. Deleterious solvent action by the acetone or alcohol added is also possible. Thus, the need for water-soluble vic-dioximes which would be devoid of these procedural pitfalls is apparent.

Feigl (21) has emphatically stressed the importance to applied analytical chemistry of a clear understanding of the constitution of the metallo-organic complexes and inner-complex compounds that are employed as the bases of

---

\*An organic reagent, to be classified as water-soluble, should be sufficiently soluble in water at room temperature to allow its being used conveniently in an aqueous solution in common analytical procedures. If the saturated aqueous solution of a reagent is so dilute that a very large volume of solution must be added in order to have present the required amount of reagent, the analytical procedure, if applicable at all, at least suffers a great reduction in speed, manipulative ease and efficiency.

analytical procedures. The whole process of developing new organic analytical reagents and of extending the scope of applicability of existing reagents certainly depends upon exhaustive studies that will lead to a more complete knowledge of the structures of these molecules.

The generally accepted structure of the compound formed by the reaction between nickel(II) ions and 2,3-butanedionedioxime accompanied by the liberation of two hydrogen ions was first proposed by Pfeiffer (60,61).

This compound, commonly drawn as (17, p. 13)

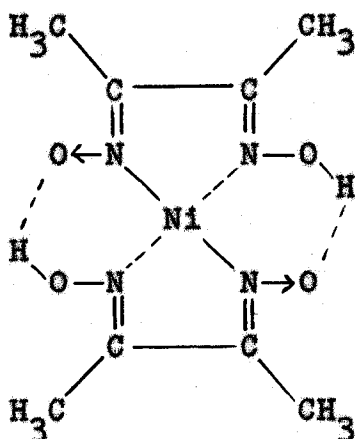

or, perhaps, more correctly (57, p. 100)

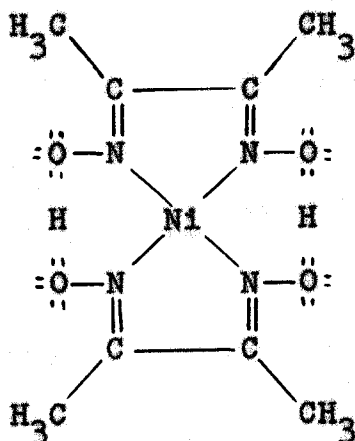

possesses great stability. The 2 chelate rings involving the nickel, 2 nitrogen and 2 carbon atoms undoubtedly account for the largest share of this stability. However, the question arises as to the amount of contribution made by the 2 rings which include the hydrogen atoms. This possible contribution would depend, perhaps, on the degree of hydrogen bonding occurring between the hydroxyl hydrogens and the neighboring oxygen atoms. Direct physical evidence for this phenomenon of hydrogen bonding and the relative strength of the bond has not been found in the literature.

The nomenclature employed for organic compounds containing the functional group

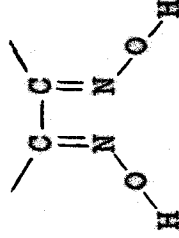

has lacked uniformity and, in some cases, clarity. For the sake of standardization, the systematic nomenclature method prescribed by the "Definitive Report of the Commission of the Reform of the Nomenclature of Organic Chemistry" as adopted by the Commission and Council of the International Union of Chemistry in 1930 (56) is followed as closely as possible. In this connection, the dioximes are named by

adding the suffix -dioxime to the name of the corresponding ketone. As an example, the compound

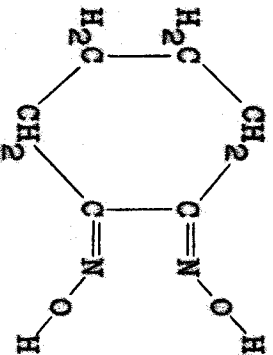

is called 1,2-cyclohexanedione dioxime (I.U.C. Rule 35).

This name is written as one word in compliance with the I.U.C. Committee rule although some American chemical journals have not adopted this form (86,90,91) or, at least, are not consistent in this practice (89). Euphonious names, such as heptoxime for 1,2-cycloheptanedione dioxime, have been suggested (89) for a few of the vic-dioximes for the purpose of brevity and convenience in oral and space-limited written communications.

The general name used by the author for a family of organic compounds containing this particular dioxime grouping is vic-dioximes (12). This prefix vic-, an abbreviation of vicinal, serves to emphasize the presence of this structural feature rather than imply the gross structural configuration of the molecule. Commonly encountered as generic names for these compounds are 1,2-dioximes, ortho-dioximes and  $\infty$ -dioximes (17, p. 1;27, p.6).

The method for naming the compounds containing oxime groups in which deuterium is substituted for the hydroxyl hydrogen of this group is taken from the "Report of Committee on Nomenclature, Spelling and Pronunciation" on the nomenclature of the hydrogen isotopes and their compounds (13). The committee, under the chairmanship of E. J. Crane, suggested a system based on the one proposed by Willis A. Boughton whereby an italic d is placed after the name of the functional group in the systematic compound name to designate the presence of deuterium in place of hydrogen. The number of deuteriums present is indicated by a subscript number placed after the d. For example, the compound

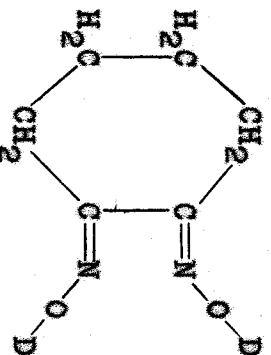

is named 1,2-cyclohexanedione dioxime-d<sub>2</sub> by this method.

The term inner-complex compound is used for coordination (also called complex) compounds that are chelate non-electrolytes. Very little attention has been paid in the past to the naming of these compounds, with the result that a systematic method of nomenclature has not been

widely adopted. However, Fernelius, Larsen, Marchi and Rollinson have proposed additions and extensions to the incomplete rules of the I.U.C. Committee to cover this field (30). For example, by this method the name for the inner-complex compound formed by the reaction of nickel(II) ions and 1,2-cyclohexanedionedioxime is 1,2-bis(1,2-cyclohexanedionedioximo-N,N')nickel(II). The first two numbers designate a planar structure, while "bis" indicates the presence of the two identical organic groups. The "o" replaces the "e" at the end of the systematic name of the dioxime to indicate that a hydrogen ion has been removed and the organic group is, in effect, an anion. The letters N and N' designate the point of attachment as being between the nitrogens of the bidentate groups and the metal ion. These letters are placed after the name of the coordinating group to prevent confusion with their use in organic nomenclature. The Roman numeral, of course, indicates the valence state of the cation.

#### B. Purpose of the Investigation

The need of a water-soluble vic-dioxime for analytical purposes is evident, as is the need for a better understanding of the structure of the inner-complex compounds that these reagents form with certain ions. For these

reasons the purpose of this investigation was twofold. First, a preparation and investigation of some alicyclic vic-dioximes as possible water-soluble reagents was undertaken. Secondly, the possibility of obtaining physical evidence, by means of infrared spectroscopy, of the nature of the hydrogen bond in these inner-complex compounds was investigated.

II. PART ONE: THE PREPARATION OF SEVERAL ALICYCLIC  
VIC-DIOXIMES AND THEIR APPLICATIONS  
TO ANALYTICAL CHEMISTRY

The review of the literature dealing with the nature of the hydrogen bond in the inner-complex compounds will be given in a later section.

A. Review of the Literature

The search for a water-soluble vic-dioxime in the past has not been limited to the preparation of new compounds. Several researchers have tried to find methods of solubilizing some of the more analytically valuable water-insoluble vic-dioximes. These efforts have been the greatest in the case of 2,3-butanedionedioxime.

Kasey (43) recommended the use of a 2 per cent solution, prepared by slowly adding a solution containing sodium hydroxide to hot water containing solid 2,3-butanedionedioxime. Semon and Damerell (73) prepared sodium 2,3-butanedionedioximate 8-hydrate by dissolving the solid dioxime in aqueous sodium hydroxide solution and then adding ethanol to precipitate the 8-hydrate. This preparation, of course, did not eliminate the use of an organic solvent. Hillebrand and Lundell (38) and also Lundell, Hoffman, and Bright (49) suggested the use of



ammonium hydroxide for making a solution of 2,3-butanedioxime when ethanol is not readily available. Such solutions were not stable for long periods of time (17, p. 20). Raithel (64) recommended preparing the 2,3-butanedione-dioxime reagent by thoroughly mixing equal weights of sodium peroxide and solid dioxime and dissolving this mixture in distilled water followed by dilution. Diehl, Henn, and Goodwine (19) pointed out the explosive hazard of preparing the reagent solution as Raithel recommended, and also showed that decomposition of such a solution was even more rapid than that of a solution of 2,3-butanedione-dioxime in 1 per cent sodium hydroxide.

The need for water-soluble 1,2-dioximes is apparent, since none of the proposed schemes to solubilize 2,3-butanedioxime have eliminated the use of an organic solvent while resulting at the same time in a stable aqueous solution of 2,3-butanedione-dioxime.

Three vic-dioximes had been reported in the literature as being water-soluble. Kuras (47,48) proposed 1,2-diaminoethanedione-dioxime (commonly called diamino-glyoxime or niccocolox) as a water-soluble micro- and macro-gravimetric reagent for the determination of nickel. This reagent, although soluble in hot water, is not appreciably soluble in cold water and, thus, can not be classed as a water-soluble reagent.

Soule (74) described 1,2-bis(2-furyl)ethanedione-dioxime, which was originally reported by Tschugaeff (84) in 1905, as a water-soluble compound suitable for the detection and determination of nickel. It has also been successfully used for the gravimetric determination of palladium by Reed and Banks (67). Again, this vic-dioxime is soluble in hot water but at room temperature its solubility in water was found to be 0.79 gram (0.0033 mole) per liter (67) which is very nearly the same as the molar solubility of 2,3-butanedionedioxime (0.40 gram or 0.0034 mole per liter).

In 1923 Wallach (93) first reported 1,2-cyclohexanedionedioxime as a precipitant for nickel(II) ions. This water-soluble vic-dioxime later proved to be a very sensitive qualitative reagent for these ions. Its solubility in water was found to be 8.2 gram (0.058 mole) per liter at room temperature (42,90) or 17 times greater than the corresponding molar solubility of 2,3-butanedionedioxime and 1,2-bis(2-furyl)ethanedionedioxime.

Thus, 1,2-cyclohexanedionedioxime appeared to be the only truly water-soluble vic-dioxime possessing promise as an analytical reagent that had been reported in the literature. For this reason a study of this compound and some of its homologs was undertaken.

Riley, Morley and Friend (69) and Dieckmann (16) reported the preparation of 1,2-cyclopentanedionedioxime as a derivative of 1,2-cyclopentanedione. The dione was prepared in very small yields by Riley, et al., by the oxidation of cyclopentanone with selenium dioxide in alcohol solution.

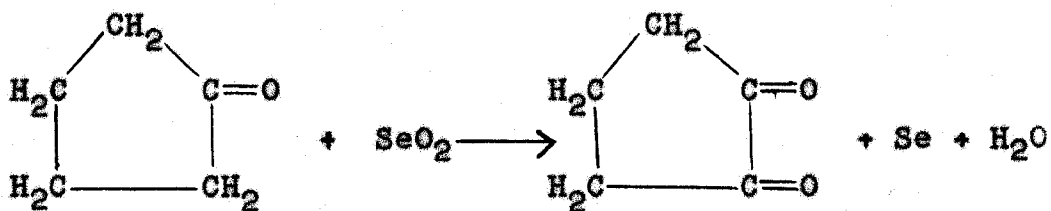

Dieckmann prepared 1,2-cyclopentanedione by boiling finely divided ethyl ester of 1,2-diketocyclopentane-3,5-dicarboxylic acid with dilute sulfuric acid. The reaction proceeded with the loss of carbon dioxide as follows:

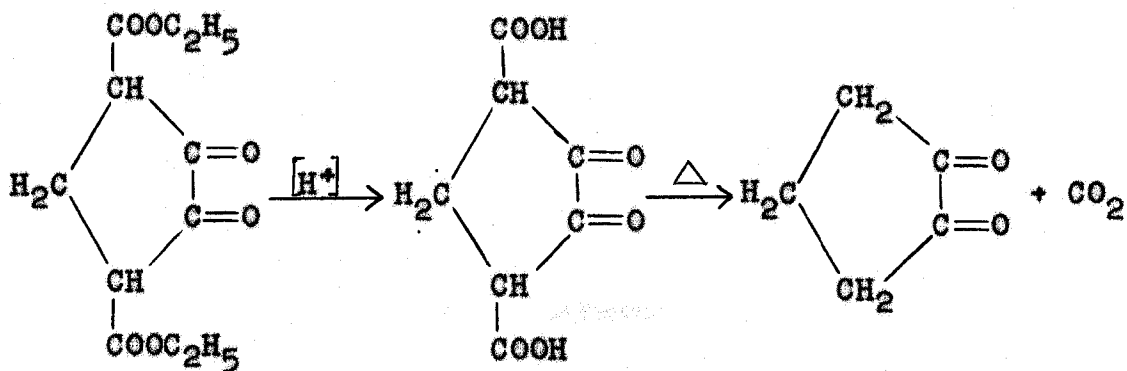

The ester was prepared by Dieckmann (15) by the condensation of the diethyl glutarate with diethyl oxalate in the presence of sodium ethylate.

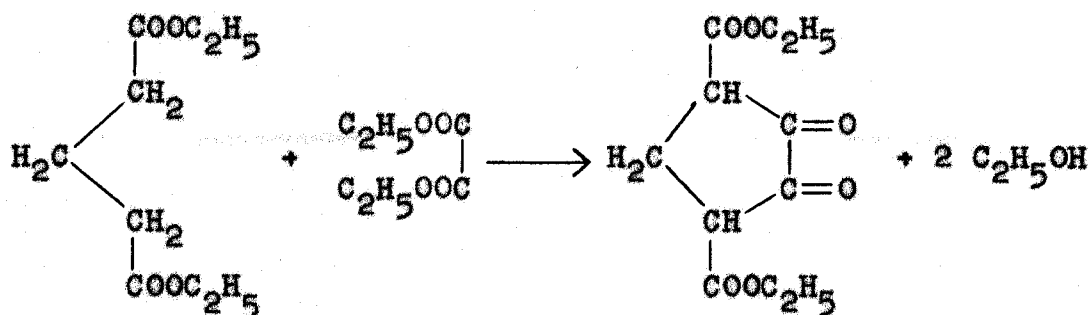

The glutaric ester was expensive to buy commercially.

The methods employed for the preparation of 1,2-cyclohexanedionedioxime were well reviewed and described in 1944 by Banks (2). In brief, this compound has been prepared, by oximating 1,2-cyclohexanedione with hydroxylammonium chloride in aqueous potassium hydroxide solution, by Wallach (93), Wallach and Weissenborn (94), Banks (2), Rauh, Smith, Banks and Diehl (66) and by Hach, Banks and Diehl (37). 1,2-Cyclohexanedione has been prepared by brominating cyclohexanone and treating the resulting 1,3-dibromocyclohexanone-2 with aqueous potassium hydroxide solution to obtain the dihydroxy compound which upon losing water yielded the dione (94). Urion's method consisted of heating divinylglycol with copper (85). Riley, Morley and Friend (69), Vène (87) and Rauh, et al., (66) employed selenium dioxide to oxidize cyclohexanone in an alcohol solution to 1,2-cyclohexanedione. Hach, Banks and Diehl (37) employed this oxidizing agent but used excess cyclohexanone as the reaction medium.

1,2-Cyclohexanedionedioxime has also been prepared by Treibs and Dinelli (32), Jaeger and van Dijk (40), Jaeger and Bijkerk (39) and Geissman and Schlatter (31) by oximating 2-isonitrosocyclohexanone-1 with hydroxylammonium chloride. Rauh, et al., oximated sodium-2-isonitrosocyclohexanone-1 with hydroxylammonium chloride in methanol solution. Tokura and Oda (80) prepared 1,2-cyclohexanedionedioxime in small yields by treating 2-chlorocyclohexanone with hydroxylammonium chloride.

The procedure of Hach, Banks and Diehl as modified by Arnold and Gordon\* appears to be superior from the standpoint of simplicity, yields and availability of starting materials. A yield of 63 per cent is obtained for the oxidation step

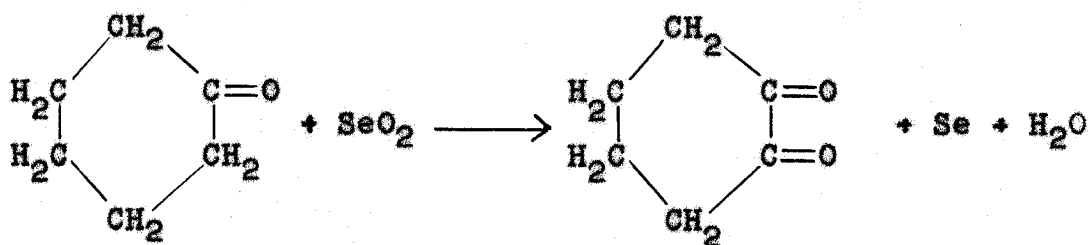

while a yield of 55 per cent was found for the oximation of the dione to the dioxime.

---

\*R. T. Arnold and Philip N. Gordon in checking this method of Hach, Banks and Diehl prior to publication in Org. Syntheses suggested several minor changes in the procedure for the preparation of 1,2-cyclohexanedione that effected a material increase in the yield.

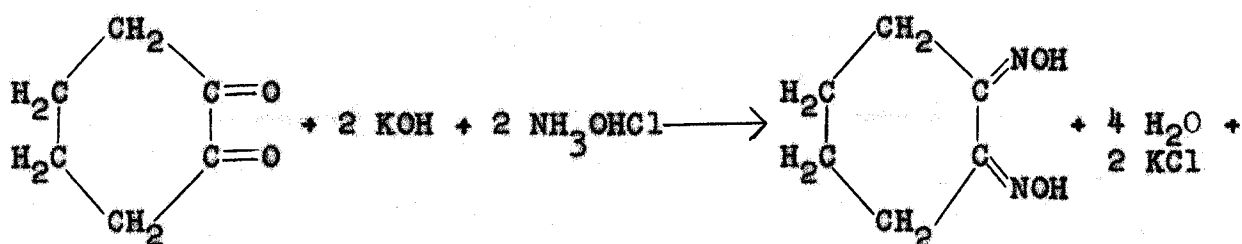

Godchot and Cauquil (33) synthesized 1,2-cycloheptanedionedioxime as a derivative of 1,2-cycloheptanedione, which they had prepared by the oxidation of cycloheptanone with selenium dioxide in an alcohol medium. Experimental details were not given for either the Riley-type oxidation or the oximation. Cycloheptanone, which was commercially available only at a prohibitive price, has been prepared by Ruzicka, et al., (72) by dry distillation of the calcium or thorium salt of octanedioic acid.

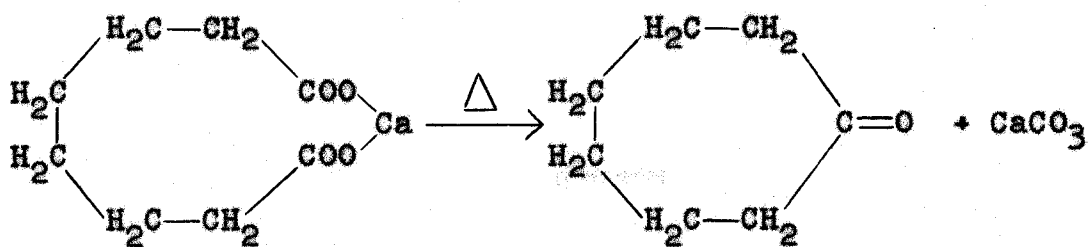

Octanedioic acid was also prohibitively expensive.

Kohler, Tishler, Potter and Thompson (46), adapting the method of Meerwein (52), converted cyclohexanone to cycloheptanone by the action of diazomethane.

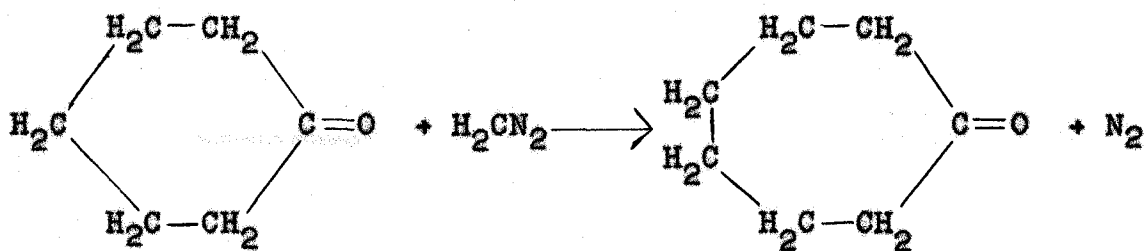

No report of the preparation of 1,2-cyclodecanedione-dioxime was found in the literature. However, Prelog, et al. (62), and Stoll, Hulstkamp and Rouvé (75,76) prepared 1,2-cyclodecanedione in connection with the synthesis of cyclodecan-1-ol-2-one. This latter compound was prepared by the intramolecular condensation of the diethyl ester of decanedioic acid with sodium in an inert solvent and nitrogen atmosphere.

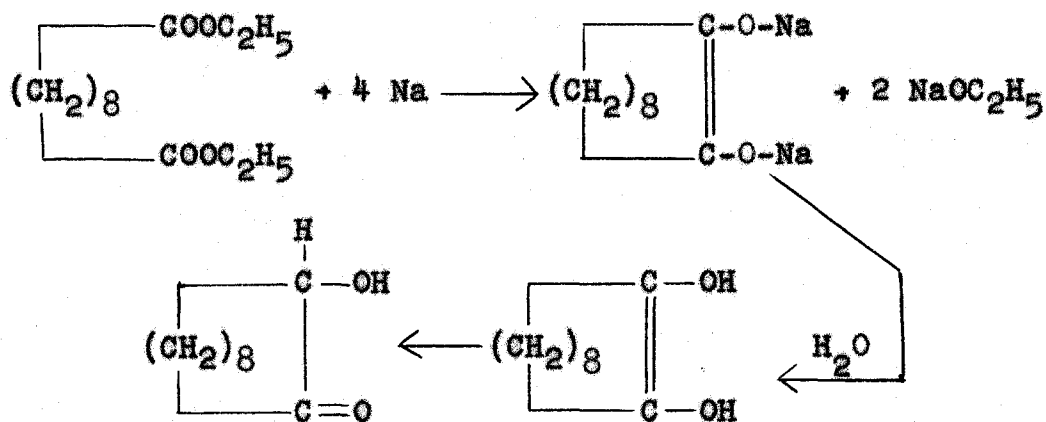

A very dilute reaction solution was employed in order to minimize intermolecular condensation.

Prior to the publication of some of the researches which will be herein reported, the published reports of the applications of the alicyclic vic-dioximes to analytical chemistry were limited to the use of 1,2-cyclohexanedione-dioxime as a semiquantitative, qualitative and colorimetric reagent. Feigl (24) in 1931 suggested this compound as a water-soluble qualitative reagent for nickel(II) ions. Wenger and Duckert (97) reported that it was a much more sensitive reagent for these ions than 2,3-butanedione-dioxime. At that time, however, the difficulty of synthesizing the vic-dioxime apparently precluded a detailed study of its properties and uses as an analytical reagent. Preparative methods developed in 1945 (66) made possible more complete investigations.

Johnson and Simmons (42) suggested 1,2-cyclohexanedione-dioxime for the colorimetric determination of nickel. They found, as did Feigl (22) and Rollet (70) in the case of 2,3-butanedione-dioxime, that 1,2-cyclohexanedione-dioxime would react with nickel(II) ions in the presence of bromine water to form an intensely colored soluble complex. They developed, however, a colorimetric method for the determination of nickel in cobalt salts and steels based on the red color formed by the reaction of nickel(II) ions with this reagent. They despaired, though, of using this reagent for the gravimetric determination of nickel



because of the slight coprecipitation of the nickel precipitate with excess reagent. Wenger, Monnier and Rusconi (98) used 1,2-cyclohexanedionedioxime to determine nickel(II) ions by a semiquantitative method based on the limit of detection of the reaction. Griffing and Mellon (36) utilized this reagent for the colorimetric determination of iron.

Since the publication of part of the author's research several papers have appeared in the literature dealing with analytical applications of the alicyclic vic-dioximes. Peltier, Duval and Duval (58) recommended 1,2-cyclohexanedionedioxime as an analytical reagent for nickel in preference to 2,3-butanedionedioxime because of its solubility in water and ability to react with this ion at a lower pH. Peshkova, Verdernikova and Gontaeva (59) reported the gravimetric determination of nickel with 1,2-cyclohexanedionedioxime and suggested methods of eliminating common interferences. Feinstein (26) published a method for the gravimetric determination of nickel in the presence of iron with this reagent. However, his procedure called for a reprecipitation of the nickel compound in order that accurate results be obtained. Feinstein also reported the results of a series of microscopical tests for nickel using this reagent.

Mathews and Diehl (51) studied the reaction of iron(II) with 1,2-cyclohexanedionedioxime and found that in the presence of ammonia or an amine this reaction provides a very sensitive test for iron. Ferguson and Banks (28) have developed a method for the spectrophotometric determination of trace amounts of nickel in calcium metal with 1,2-cyclohexanedionedioxime. Their direct, accurate procedure employed gum arabic for the purpose of stabilizing the nickel(II) inner-complex compound.

Ferguson and Banks (27,29) were the first to study the reaction of 1,2-cycloheptanedionedioxime in the presence of oxidizing agents in strongly basic solutions. They reported that the reddish-brown complexes, which are similar to those produced under the same conditions by 2,3-butanedionedioxime and 1,2-cyclohexanedionedioxime, provided a more sensitive method for the spectrophotometric determination of nickel. Butts, Gahler and Mellon (9) have described a procedure for determining nickel colorimetrically with 1,2-cycloheptanedionedioxime based on the above work of Ferguson and Banks. The determination, which involved a preliminary extraction with chloroform as a separation method, was carried out, however, in an acidic solution in the presence of an oxidant. The authors claimed that these oxidized complexes are more

stable than the corresponding oxidized nickel complexes formed with 2,3-butanedionedioxime.

### B. Materials and Apparatus

In general, only chemicals of reagent-grade, Eastman white label grade or comparable purity were employed. The chemicals and solutions that were specially prepared or purified for this work will be described.

Cyclopentanone. This cyclic ketone was prepared according to the procedure given in Org. Syntheses (79) and modified by Wagner (92). This method involved the dry distillation of adipic acid in the presence of small amounts of barium hydroxide.

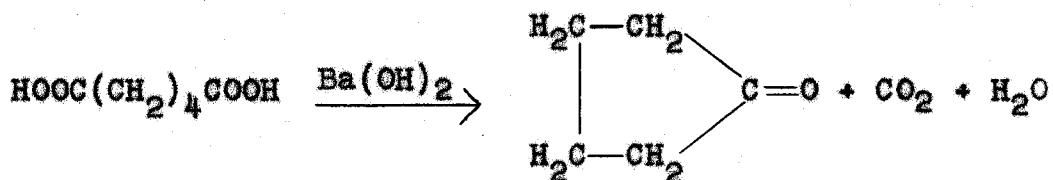

The cyclopentanone in the distillate was separated from the water and small amount of adipic acid that accompanied it by salting out with potassium carbonate. Pure cyclopentanone was obtained by distillation, b.p. 128-131°, in a yield of 66 per cent.

Selenium dioxide. The method of Riley and Gray (68) was employed for the preparation of selenium dioxide.

This procedure involved the oxidation of selenium with nitric acid. The dioxide was carefully heated to remove the last traces of water and nitric acid. In one case, the dioxide was sublimed in order to obtain maximum purity.

Standard nickel(II) chloride solutions. These solutions were prepared from Mond nickel obtained from the International Nickel Company, New York. An analysis supplied by Mr. J. G. Dean of that company showed that this nickel contained 0.045 per cent iron and 0.008 per cent each of cobalt and copper. Weighed amounts of the nickel were dissolved in aqua regia and the solution evaporated to dryness 5 times with concentrated hydrochloric acid to eliminate nitrate ions. By weighing the diluted nickel(II) chloride solution the weight of nickel per weight of solution (approximately 0.002 gram nickel per gram of solution) was found. This nickel concentration was also checked by electrolytic determination of the nickel, the samples being measured by use of a weight buret. The standard nickel(II) chloride solution (0.474 mg. nickel per gram of solution) used for the work on the micro-determination of nickel with 1,2-cycloheptanedionedioxime was prepared by diluting some of the more concentrated standard nickel(II) chloride solution.

The nickel content of this solution was obtained by determining the nickel in weighed amounts of the solution with 1,2-cycloheptanedionedioxime.

Standard palladium(II) chloride solution. Commercial palladium(II) chloride was purified by first precipitating out any platinum present as ammonium chloroplatinate (81) and then precipitating the palladium as 1,2-bis(2,3-butanedionedioximo-N,N')palladium(II). This inner-complex compound was destroyed with aqua regia and the solution evaporated to near dryness 5 times with concentrated hydrochloric acid to eliminate nitrate ions. The palladium content of the diluted acidic palladium(II) chloride solution (0.001993 gram of palladium per gram of solution) was determined by precipitating the palladium in weighed amounts of solution with 2,3-butanedionedioxime. The solutions were allowed to stand overnight to insure complete precipitation of the palladium compound. Spectrographic analysis indicated that this solution was sufficiently pure for its intended purpose.

1,2-Cycloheptanedionedioxime solution. A 0.47 per cent aqueous solution was prepared from the dioxime synthesized in this laboratory.

1,2-Cyclohexanedionedioxime solution. A 0.8 per cent aqueous solution was made up from reagent obtained from the Hach Chemical Company, Ames, Iowa

2,3-Butanedionedioxime solution. Mallinckrodt analytical-reagent 2,3-butanedionedioxime was used to make a 1 per cent solution in ordinary 95 per cent ethanol.

The following solutions for the work on the micro-determination of nickel were made up by dissolving the reagent-grade chemicals in water: citric acid solution, 0.45 gram per ml. of solution; sodium sulfite solution, 1 gram per 10 ml. of solution; ammonium thiocyanate solution, 1 gram per 2 ml. of solution; ammonium acetate, 1 gram per 5 ml. of solution.

Most of the apparatus used in this work was from commercially available stock. Only uncommon or specially prepared items will be mentioned.

Beckman pH meters, the line-operated model H-2 meter and battery-operated model M meter, were used for determining the pH of solutions in the macro-scale operations.

Glass apparatus equipped with interchangeable ground-glass joints (trademarked "Inter-Joint" and obtained from the Scientific Glass Apparatus Company, Bloomfield, New Jersey) was employed almost exclusively.

Precipitation of 1,2-bis(1,2-cycloheptanedionediox-imo-N,N')nickel(II) on the micro-scale was carried out in the Emich and Schwarz-Bergkampf type of micro-filter beaker (available from the Arthur H. Thomas Company, Philadelphia, Pennsylvania), which contains a fritted-glass disc fused into a side arm with a constricted end. The maximum manipulatable capacity of these beakers is approximately 4 ml. The nickel precipitate is only slightly hygroscopic, and a glass bead placed in the small mouth of the beaker after drying effectively eliminated any appreciable gain in moisture content during the weighing. Identical tares for the beakers were used throughout the work.

A steam bath for the digestion of the precipitates was prepared by suspending a wire-mesh tray in the upper half of an 800-ml. beaker. The micro-filter beakers were placed on microscope slides resting on the tray. The digestion temperature was obtained by boiling water in the large beaker.

A 30-ml. weighing bottle having the ground zone on the outside of the body was fitted with a 25-mm. glass-enclosed stirring bar for use with a magnetic stirring apparatus.

A 10-ml. Grethen type weighing bottle (available from the Arthur H. Thomas Company) was used to weigh portions of

the solution into the micro-filter beakers before precipitation with 1,2-cycloheptanedionedioxime. This weighing bottle consisted of a body which contained the solution and a pipette from which the solution was dispensed.

An apparatus for filtering dehydrated silica from a solution on the micro-scale consisted of a small glass funnel (19 mm. in diameter at the top) shaped like a Buchner funnel and similarly fitted with a perforated porcelain disc. This funnel and a bent glass tube for applying reduced pressure were placed in the holes of a large two-holed rubber stopper which in turn was fitted to a shallow, large-mouthed glass bottle. The bottle was large enough to accommodate the 30-ml. weighing bottle.

An apparatus for filtering the 1,2-bis(1,2-cycloheptanedionedioximo-N,N')nickel(II) consisted of a 50-ml. filter flask fitted with a one-holed rubber stopper. A short section of small-bore glass tube with 2 inches of small-sized rubber pressure tube placed on top was inserted in the stopper. In filtration the tip of the side arm of the micro-filter beaker was inserted in the rubber tube.

### C. Experimental Methods and Results

The preparation and investigation of the analytical properties of 4 alicyclic vic-dioximes will be considered



individually in this section. The study of the structures of their nickel and palladium derivatives will be discussed under a separate heading (Section III).

1. 1,2-Cyclopentanedionedioxime

The members of this alicyclic vic-dioxime series will be taken up in order of their increasing carbon content. Thus, the cyclopentane derivative, although one of the least important from an analytical standpoint, appears first.

(a) Preparation. The method of Riley, Morley and Friend (69) for the preparation of 1,2-cyclopentanedione was tried. Four times the amounts of materials used by these researchers were employed, as follows:

A solution of 168 grams (2.0 moles) of cyclopentanone in 800 ml. of ethanol was placed in a flask fitted with a reflux condenser. A solution of 208 grams (1.9 moles) of selenium dioxide in 1200 ml. of ethanol was added dropwise to the refluxing mixture over a period of 2 hours. After an additional 2 hours of refluxing, the more volatile liquids were distilled off and the remaining liquid decanted from the metallic selenium. The residual liquid was saturated with sodium chloride and then extracted with ether, the ether extract being dried with calcium chloride.

Another run using these steps was made and the ether extracts from both were combined before the ether was removed by distillation. The 90 grams of liquid that remained was distilled under reduced pressure, with a large first fraction containing cyclopentanone and some water being collected. The second fraction yielded 30 grams of a yellow oil which darkened, boiling over the range  $85^{\circ}$  to  $105^{\circ}$  at 20-21 mm. Upon redistillation from a flask partially filled with glass wool to prevent violent bumping, 7 grams of a light yellow oil of b.p.  $79-83^{\circ}$  at 4 mm. was collected. This product would not solidify on cooling, had an odor of garlic, and turned reddish-brown on standing overnight. The order of magnitude of the yield, representing only a few per cent, is in rough agreement with that obtained by Riley, Morley and Friend. They indicated that their product was also of doubtful purity. Dieckmann (16) has described 1,2-cyclopentanedione as a crystalline mass, m.p.  $55-60^{\circ}$ .

In the hope of finding a more lucrative but still comparatively simple method for the preparation of the dione, a technique was tried whereby cyclopentanone itself was used as the reaction solvent. Hach, Banks and Diehl (37) had successfully used a similar procedure for the selenium dioxide oxidation of cyclohexanone to 1,2-cyclohexanedione. A typical run is described:

In a 2-liter flask, equipped with an efficient stirrer and thermometer and submersed in a water bath, was placed 500 grams (5.95 moles) of cyclopentanone. Two hundred sixty-five grams of finely ground selenium dioxide (2.4 moles) was added in 4 portions at 2 hour intervals. A red color, indicative of the presence of elemental selenium, was noted 1 hour after the addition of the first portion of the oxidant. The temperature of the system remained constant at about 14°. After 48 hours the stirrer was stopped and the system allowed to stand for 3 days before filtration for the removal of the deposited selenium. One hundred thirty-five grams of selenium of the original 189 grams (added as selenium dioxide) was recovered. Over an additional period of 17 days more selenium was deposited from solution, occasional filtration yielding amounts not exceeding 1 gram at a time. At the end of this time the mixture was distilled under reduced pressure. A second fraction consisting of 27 grams of a yellow oil was collected over a range of 50° to 75° at 4 mm. This oil yielded upon redistillation a first fraction of cyclopentanone and water and a second fraction of 5.5 grams of a yellow oil at 4 mm. which solidified upon cooling, m.p. 46-47°. The thermometer apparently did not reach equilibrium during redistillation of the second fraction, as all the material was collected before the temperature

reached 75°. Again the yield of 1,2-cyclopentanedione represented only a few per cent but the product compared more favorably in purity with that reported by Dieckmann.

It is to be noted that a large amount of the selenium (about 50 grams) was not deposited before the distillation was carried out. Of the 135 grams recovered from the first filtration, about 75 grams was present as the dioxide. This was recovered by boiling the water used to wash the selenium and organic matter. Apparently some selenium dioxide remained unreacted.

Attempts to obtain a more complete reaction of the selenium dioxide were made by allowing a higher reaction temperature. However, whenever a water bath was not employed the reaction became violent and the reaction mixture was rapidly spewed from the flask. In one case, 30 hours after addition of the selenium dioxide the water bath was removed to allow the temperature to rise. One hour later the temperature was noted at 80°. Before the water bath could be replaced, the reaction became violent and a considerable portion of the reaction mixture was lost.

The 1,2-cyclopentanedione was oximated to 1,2-cyclopentanedionedioxime by the following typical procedure:

Two and one-half grams (0.026 mole) of dione was added to 50 ml. of a solution containing 3.6 grams (0.064 mole) of potassium hydroxide and 4.5 grams (0.065 mole) of hydroxylammonium chloride. After the reaction mixture had been maintained at 60° for 2 hours (formation of product was observed soon after addition of the dione), the reaction solution was brought to boiling. Enough water was added to bring the dioxime into solution. A small amount of norite was added and the solution filtered. The product filtered from the cooled filtrate was again crystallized from water, with norite being used as before. A yield of 0.8 gram of 1,2-cyclopentanedionedioxime, m.p. 230-234° (with decomposition), was obtained. This product was analyzed for nitrogen by the Dumas method (micro-scale); N calculated, 21.9 per cent; N found, 21.9 21.9 per cent.

The observed melting point of this compound was quite indefinite as melting and carbonization occurred simultaneously. Dieckmann (16) reported the melting point of the dioxime (prepared as an identifying derivative) as 210°. Riley, Morley and Friend (69) reported 208°. Perhaps there was a difference in the purity of the respective samples.

(b) A study of some of its properties. 1,2-Cyclopentanedionedioxime was found to react with nickel(II) and

palladium(II) ions to yield red and yellow precipitates, respectively. The former precipitate was very sensitive to the action of acids and bases and did not form in solution containing the dioxime and nickel(II) ions at pH values below about 6.0 and above approximately 8.6. However, even though a 40 per cent excess of 1,2-cyclopentanedionedioxime was present, quantitative precipitation of nickel(II) ions in solution was not observed in this range. The solubility of 1,2-bis(1,2-cyclopentanedionedioximo-N,N')nickel(II) in water at 22° (observed pH was 7.2) was determined to be 0.0024 gram nickel per 100 ml.

The red precipitate was analyzed and found to contain 18.84 per cent nickel. This procedure was carried out by decomposing a weighed quantity of precipitate with nitric acid and determining the weight of the nickel released, by precipitation with 2,3-butanedionedioxime. The theoretical nickel content of the compound formed by the combination of two 1,2-cyclopentanedionedioxime molecules for each nickel atom was calculated as 18.75 per cent.

The solubility of the dioxime in water, 1.3 grams or 0.01 mole per liter at 24°, was determined by placing a weighed quantity of the dioxime in a weighed beaker. Hot water was added and the system allowed to stand with

occasional stirring for 22 hours. The dioxime that did not dissolve was filtered off, dried and weighed. This procedure served to measure the weight of 1,2-cyclopentanedionedioxime dissolved and the weight of water as solvent.

## 2. 1,2-Cyclohexanedionedioxime

The short name, nioxime, was first proposed for this reagent by Rauh, Smith, Banks and Diehl (66) and has become frequently used in the literature (26,42,90). The methods for its preparation have been discussed elsewhere.

(a) Use as a gravimetric and qualitative reagent for nickel. The report of a study of 1,2-cyclohexanedionedioxime as a reagent for nickel has been published by Voter, Banks and Diehl (90). In order to avoid unnecessary repetition, this material is given here in summary form only.

1,2-Cyclohexanedionedioxime, a white crystalline material of m.p. 189-190°, is soluble in water to the extent of 8.2 grams per liter at 21.5°, thus allowing the use of aqueous solutions in analytical methods. As a qualitative reagent, it was found to produce almost immediately a red-to-pink coloration with nickel(II) ions in concentrations down to 1 part in 10,000,000. Precipitation

of nickel(II) ions with 1,2-cyclohexanedionedioxime to yield a scarlet red precipitate was found to be quantitative at pH values of 3 and greater. Quantitative filtration of 1,2-bis(1,2-cyclohexanedionedioximo-N,N')nickel(II), precipitated slowly and in solutions of pH values below 7, was not difficult or tedious providing nickel sample sizes were restricted to 25 mg. or less. Slow precipitation was accomplished by gradually raising the pH by addition of ammonium acetate solution from a point of incipient precipitation. Excess reagent apparently coprecipitated to a small extent with the nickel precipitate causing a slight positive error. The magnitude of this deviation closely approximated a linear function of the excess 1,2-cyclohexanedionedioxime present. An empirical equation was developed from which the correct results for nickel can be calculated. In general, this equation was not used for amounts of nickel less than 15 mg.

The nickel compound was precipitated without interference in solutions containing tartrate, acetate, sulfosalicylate, nitrate, chloride, sulfate and perchlorate ions and the following metallic ions: uranium(VI), manganese(II), sodium, potassium, lithium, barium, calcium, strontium, magnesium, cadmium, arsenic(III), beryllium, zinc, aluminum and antimony(III). The latter 2 cations were complexed



with tartrate. A complexing agent which would allow the satisfactory quantitative separation of nickel from iron was not found.

(b) Use as a gravimetric reagent for palladium. A paper reporting the results of an investigation of 1,2-cyclohexanedionedioxime as a quantitative gravimetric reagent for palladium(II) ions has been published by Voter, Banks and Diehl (91). A brief review of this material is given here.

Water-soluble 1,2-cyclohexanedionedioxime reacts with palladium(II) ions to yield a yellow insoluble inner-complex compound which can be used for the quantitative determination of these ions. While this reagent appeared to be more sensitive than 2,3-butanedionedioxime as a qualitative reagent for palladium(II) ions, the weak color of the precipitate indicated that both of these vic-dioximes are unsatisfactory for this purpose at low concentrations unless the utmost care is exercised. Solutions containing 1 part in 2,000,000 of palladium(II) ions exhibited a slightly yellow coloration 5 minutes after the addition of 1,2-cyclohexanedionedioxime solution.

1,2-Bis(1,2-cyclohexanedionedioximo-N-N')palladium(II) was precipitated from dilute mineral acid solutions; quantitative precipitation was found to occur at pH values

above 0.7. Determinations were successfully carried out on palladium samples over the range of 6 to 30 mg. However, filtration was difficult and tedious in the case of the larger samples. As much as 150 per cent excess reagent was added without affecting the accuracy of results obtained. Chloride, sulfate, nitrate, acetate, tartrate and sulfosalicylate ions and the following cations did not interfere with the determination of palladium: platinum, uranium(VI), ruthenium(III), beryllium, sodium, potassium, lithium, barium, strontium, calcium, aluminum, lanthanum, zinc and cadmium. The precipitate was filtered from a hot solution after a brief digestion period without apparent loss by solubility.

### 3. 1,2-Cycloheptanedioxime

The techniques involved in the macro- and micro-gravimetric determination of nickel(II) ions with 1,2-cycloheptanedioxime are sufficiently different to warrant their being discussed individually.

(a) Preparation. Since a detailed procedure for the synthesis of 1,2-cycloheptanedioxime has been worked out and published by Vander Haar, Voter and Banks (86), only a short review of the procedural steps will be given at this point.

1,2-Cycloheptanedione was prepared by the oxidation of cycloheptanone with an equimolar amount of sublimed selenium dioxide in ethanol solution. The diketone, a deep yellow liquid of b.p. 107-109° at 17 mm., was obtained in a 90 per cent yield.

The dioxime was prepared by slow addition of the diketone in methanol to a cooled, stirred, water-methanol solution containing equimolar quantities of hydroxylammonium chloride and sodium hydroxide. The product obtained was recrystallized from water, m.p. 179-180°, and represented a 46 per cent yield based on the amount of dione used. Thus, an over-all yield of approximately 40 per cent was obtained.

(b) Use as a macro-gravimetric reagent for nickel.

A complete report of the study of 1,2-cycloheptanedione-dioxime as a macro-gravimetric reagent for nickel has been published in the recent literature by Voter and Banks (89). A brief summary of the findings is as follows:

The solubility of 1,2-cycloheptanedionedioxime in water was determined to be 4.8 grams (0.031 mole) per liter at 19.5°. Aqueous solutions of this reagent can therefore be employed conveniently in analytical methods. The dioxime reacts with nickel(II) ions to form a yellow

inner-complex compound, precipitation being quantitative at pH 2.7 and greater. Satisfactory gravimetric results were obtained with the techniques used, with samples of nickel ranging from 6 to 61 mg. A large excess of reagent did not noticeably affect the results, indicating that coprecipitation of the reagent with the nickel precipitate was negligible. In a study of the effect of common anions on this determination it was found that acetate, tartrate, chloride, citrate, perchlorate, sulfate, sulfosalicylate, nitrate and thiocyanate did not interfere. Nickel was determined in the presence of aluminum, chromium(III), manganese(II), lead(II), magnesium, zinc, cadmium, antimony(III), arsenic(III), beryllium, iron(III), molybdenum(VI), titanium(IV), copper(I), cobalt(II), vanadium(V) and bismuth ions. Aluminum, chromium(III), antimony(III), arsenic(III), iron(III), titanium(IV), and bismuth ions, when present, must be complexed with either tartrate or citrate to prevent their coprecipitation as hydroxides. Cobalt(II) ions react with 1,2-cycloheptanedionedioxime to form a brown complex compound which remains in solution if the cobalt concentration is not too high. Copper ions react with the reagent, yielding an insoluble brown precipitate. However, this interference is eliminated by taking advantage of the fact that copper(I) thiocyanate is soluble in excess

thiocyanate. The soluble complex formed effectively masks the copper(I) ions and prevents their reaction with 1,2-cycloheptanedioneoxime. Acetate is added to prevent the precipitation of lead(II) chloride when lead is present.

A procedure for determining nickel in steel containing both cobalt and copper was developed and tried with success on 5 National Bureau of Standards steels. An aluminum-base alloy was also analyzed for nickel. The reliability and simplicity of this method was successfully tested by an analyst unfamiliar with the procedure. These data are shown in Table 1.

During the development of the procedure for the analysis of steels for nickel, it was noted that a yellow precipitate often resulted if ammonium thiocyanate was added to an aqueous solution containing small amounts of nitric acid (pH 0.5 to 1.0). This reaction was accompanied by the formation of gaseous bubbles and occurred when the solution was heated to about 60°. At higher pH values (4.0 and above) the phenomenon was not observed even at temperatures near boiling. Some of the yellow compound was filtered off, dried and analyzed for nitrogen by the Kjeldahl method (100). Results of 18.5 and 18.4 per cent nitrogen were obtained. The compound, before this analysis, was thought to be perthiocyanic acid,  $C_2N_2S_3H_2$ , or

Table 1

Determination of Nickel in Steel and an Aluminum Alloy  
with 1,2-Cycloheptanedionedioxime

Material	Nickel Present %	Nickel Found %	Average Found %
N.B.S. Nickel Steel No. 33c	3.28	3.25 3.26 3.27	3.26
N.B.S. Cast Iron No. 115	15.89	15.82 15.93 15.94 15.84	15.88
N.B.S. Nickel-molybdenum Steel No. 111a	1.75	1.75 1.75 1.74* 1.75*	1.75
N.B.S. 18 Chromium-9 Nickel Steel No. 101c	9.27	9.29 9.26 9.23# 9.28#	9.28 9.26
N.B.S. Chromium-nickel-molybdenum Steel No. 139	0.563	0.558 0.556	0.557
N.B.S. Aluminum-base Alloy No. 85a	0.41	0.42 0.42	0.42

\*To these samples were added 5 mg. Cu(II) and 5 mg. Co(II). Samples contained 22.5 and 24.5 mg. nickel respectively.

#Analysis run by analyst unfamiliar with this procedure.

thiocyanuric acid,  $C_3N_3S_3H_3$ , (50) which contain 18.7 and 23.8 per cent nitrogen respectively. Apparently the former compound was the correct one.

(c) Use as a micro-gravimetric reagent for nickel.

The successful application of 1,2-cycloheptanedionedioxime to the macro-gravimetric determination of nickel(II) ions suggested a similar investigation of this reagent in the micro-range (89). It was assumed that properties such as the effect of various anions, cations and excess reagent, and the minimum pH for quantitative precipitation observed on the larger scale would remain the same in micro-scale operations.

In order to find the range of nickel samples that could be conveniently and accurately determined, samples of the standard nickel(II) chloride solution (0.474 mg. nickel per ml. of solution) were carefully weighed into micro-filter beakers from a weight buret. Four drops of ammonium acetate solution and 1 drop of 1 per cent hydrochloric acid were added to each sample. The solutions were next diluted to about 2.5 to 3 ml. total volume with water. The pH values were checked with "Phydrion Paper" and adjusted as necessary to fall in the range 3.5 to 5.5. 1,2-Cycloheptanedionedioxime was added (at least 0.15 ml. per 100  $\mu$ g. of nickel present) from a calibrated glass

dropping bottle pipette (ground-in type). When held vertically this particular pipette delivered 27 drops per ml. The solution was stirred by careful swirling and then digested for 10 minutes in the steam bath.

During this digestion period coagulation of the precipitate occurred. The solutions were filtered while hot. Prior to filtration the tip of the filter beaker was moistened with glycerol to facilitate inserting it into the rubber tube of the filter apparatus. After filtration the tip was wiped with a cotton gauze moistened with 50 per cent methanol solution. The precipitates were washed with 5 portions of water dispensed from a 30-ml. medical type hypodermic syringe. The filter beakers were dried along with their tares and respective glass beads for an hour at 110-120°.

Experimental results indicated that amounts of nickel in the range 50  $\mu$ g. to 1 mg. could be determined conveniently and successfully. Below this limit results were unreliable. Amounts of nickel greater than 1 mg. yield precipitates too voluminous and bulky for satisfactory quantitative manipulation. Data obtained are shown in Table 2.

Preliminary experiments on the application of these methods to the micro-determination of nickel in steel



Table 2  
Analysis of Standard Nickel Solutions  
with 1,2-Cycloheptanedionedioxime

Nickel Taken $\mu$ G.	Nickel Found $\mu$ G.	Error $\mu$ G.
53	50	-3
83	82	-1
104	100	-4
238	236	-2
498	500	+2
977	985	+8

indicated that the main problem involved the quantitative removal of silica and the subsequent introduction of the sample solution into the Emich beaker. It was found that reduced pressure filtration through paper permitted a complete quantitative transfer together with adequate washing. The silica filtration apparatus previously described was assembled for this purpose. Use of a weighing bottle with the ground zone on the outside of the bottle made possible the employment of a ground-in glass cover without the danger of the solution contacting the ground zone during addition of reagents and stirring. Magnetic stirring appeared to be the most convenient method of mixing since it produced a minimum of splashing and required no rinsing.

These findings and those observed in the macro-determination of nickel with 1,2-cycloheptanedionedioxime led to the following procedure, recommended for the micro-determination in copper- and cobalt-containing steels:

Weigh the sample into a 25-ml. Erlenmeyer flask, and dissolve it in an appropriate acid or acid mixture. Treat the solution with several drops of nitric acid to decompose any carbides. Add 0.5 ml. of 60 per cent perchloric acid. Boil for 15 minutes after fuming begins. Add 4 volumes of water, and, after dissolving any salts, filter off the

silica, using 4 ml. of wash water and catching the filtrate in a previously weighed 30-ml. weighing bottle equipped with the stirring bar. While utilizing the magnetic stirrer, add to the filtrate 0.15 ml. of citric acid solution for each 10 mg. of sample taken. If lead is present, add 3 or 4 drops of ammonium acetate solution. Add 0.3 ml. of sodium sulfite solution. Adjust the pH to 3.5 with dilute ammonium hydroxide. Add 0.7 ml. of ammonium thiocyanate solution. Continue stirring until any precipitate of copper(I) thiocyanate dissolves. If the dissolution of this precipitate is slow, add more ammonium thiocyanate solution. As soon as the solution is clear, replace the cover and weigh the weighing bottle with its contents (about 9 grams). Transfer most of the solution to a Grethen weighing bottle and weigh out portions (about 3 grams) into the micro-filter beakers. To these weighed solutions add 0.1 ml. of 1,2-cycloheptanedionedioxime solution for each 50  $\mu$ g. of nickel present. Gently swirl the beaker, taking care that the solution does not contact the fritted glass. Digest for 10 minutes with occasional swirling. Allow the micro-filter beaker to stand in cool water for 30 minutes. Filter with suction. Wash with water and dry at 110-120° for at least 1 hour before weighing. The factor for nickel is 0.1590.

By using the proper complexing agents, this procedure can be adapted readily to the determination of nickel in the presence of any of the metallic ions mentioned previously. Ammonium acetate solution is added as the buffer when citrate or tartrate is not used. The pH of the solution should be about 4.0.

This procedure was tested by analyzing standard steel samples of the United States National Bureau of Standards. Results are shown in Table 3. In each case the steel samples weighed about 30 mg.

(d) Use as a gravimetric reagent for palladium. The successful application of 1,2-cycloheptanedionedioxime to the determination of nickel(II) ions naturally led to an investigation of this precipitant as a possible analytical reagent for palladium(II) ions.

1,2-Cycloheptanedionedioxime was found to react quantitatively with palladium(II) ions to yield a yellow precipitate at pH 0.8 or greater. Incomplete precipitation occurred at pH values below this figure. The weights of the precipitates resulting from the reaction of excess dioxime with a known quantity of palladium(II) ions indicated that 2 vic-dioxime molecules reacted with 1 palladium(II) ion to yield the typical inner-complex compound.

Table 3  
Analysis of Standard Steel Samples  
with 1,2-Cycloheptanedionedioxime

Material	Nickel Present %	Nickel Found %	Average Found %
N.B.S. Nickel-molybdenum Steel No. 111a	1.75	1.73	
		1.78	
		1.75	1.75
N.B.S. Chromium-nickel- molybdenum Steel No. 139	0.563	0.580	
		0.571	0.576

The factor for palladium in 1,2-bis(1,2-cycloheptanedione-dioximo-N,N')palladium(II) is 0.2558.

A series of determinations was conducted on various sizes of palladium samples. The solution volume was about 200 ml. and pH 2 to 2.5 in each case. After slow addition of the dioxime the solutions were digested for 10 minutes at about 90°, allowed to stand for 1 hour before filtering through a weighed crucible. The precipitate was dried at 110-112° for 1 hour before weighing. The data shown in Table 4 indicated that amounts of palladium in the range of 7 to 42 mg. were determined successfully. However, quantitative manipulations were difficult in the case of the largest sample.

The effect of various common anions on the determination of palladium was studied in the usual manner. The anions were added as their sodium, potassium or ammonium salts except in the case of tartrate or citrate, which were added as the acids. Chloride, acetate, sulfate, nitrate, citrate, tartrate, and perchlorate did not interfere (Table 5).

The results of several determinations of palladium in which the per cent excess of the dioxime was varied are shown in Table 6. While it was evident that excess reagent

Table 4

Determination of Various Amounts of Palladium  
with 1,2-Cycloheptanedionedioxime

Det'n	Nickel Taken gram	Weight of Precipitate gram	Nickel Found gram	Error mg.
1.	0.0070	0.0276	0.0071	+0.1
2.	0.0165	0.0648	0.0166	+0.1
3.	0.0270	0.1058	0.0271	+0.1
4.	0.0424	0.1661	0.0425	+0.1

Table 5  
Effect of Various Anions on the Determination of  
Palladium with 1,2-Cycloheptanedionedioxime

Anion Present	Anion grams	Nickel Taken gram	Weight of Precipitate gram	Nickel Found gram	Error mg
Chloride	2.0	0.0228	0.0894	0.0229	+0.1
Acetate	2.3	0.0233	0.0911	0.0233	0.0
Sulfate	2.6	0.0234	0.0920	0.0235	+0.1
Nitrate	2.3	0.0220	0.0867	0.0222	+0.2
Citrate	2.0	0.0230	0.0897	0.0229	-0.1
Tartrate	2.0	0.0227	0.0882	0.0226	-0.1
Perchlorate	2.4	0.0236	0.0925	0.0237	+0.1



Table 6  
Effect of Excess 1,2-Cycloheptanedionedioxime on  
the Determination of Palladium

Det'n	Excess Added %	Nickel Taken gram	Weight of Precipitate gram	Nickel Found gram	Error mg.
1	20	0.0221	0.0872	0.0223	+0.2
2*	30	0.0226	0.0886	0.0227	+0.1
3	80	0.0231	0.0916	0.0234	+0.3
4*	80	0.0218	0.0854	0.0218	0.0
5#	120	0.0236	0.0922	0.0236	0.0
6	150	0.0212	0.0838	0.0214	+0.2
7	250	0.0210	0.0828	0.0212	+0.2
8#	350	0.0221	0.0864	0.0221	0.0

\*Two grams of ammonium acetate also present.

#Three grams of ammonium acetate also present.

did not cause an appreciable error in the results, the samples to which 2 or 3 grams of ammonium acetate were added exhibited less positive deviation than those containing no acetate. The cases studied are too few to make a conclusive statement concerning the effect of the ammonium acetate, but the results are in qualitative agreement with those found in a similar study of this reagent with nickel ions.

The effect of several cations was studied. When iridium(IV) (0.01 gram) and rhodium(III) (0.01 gram) were present in solution, the 1,2-bis(1,2-cycloheptanedione-dioximo-N,N')palladium(II) would not coagulate in the usual manner and passed through the filter crucible. One gram of iron(III) when complexed with citric acid did not affect the results obtained. Platinum(IV) in quantities of 50 and 100 mg. caused a positive error ranging from 0.3 to 0.5 mg. A determination of palladium was made in which 100 mg. of platinum(IV) as chloroplatinic acid solution was added after the palladium had been precipitated with the vic-dioxime. In this case a positive error was not noted, which indicated that there was no palladium impurity in the platinum(IV) solution and that the positive error was probably due to coprecipitation of a complex of platinum(IV) and 1,2-cycloheptanedionedioxime with the 1,2-bis(1,2-cycloheptanedionedioximo-N,N')palladium(II).

The presence of large amounts of chloride ion did not effectively mask the platinum(IV) ions, which slowly form a flocculent purple precipitate with 1,2-cycloheptanedionedioxime in solution at pH about 2.

#### 4. 1,2-Cyclodecanedionedioxime

No attempt was made to prepare the 8 and 9 carbon members of this homologous series of alicyclic vic-dioximes but, rather, attention was directed to preparation and study of the cyclodecane derivative.

(a) Preparation. A method for the preparation of cyclodecan-1-ol-2-one (sebacoin) is described by Stoll and Hulstkamp (75) and Stoll and Rouvé (76). A procedure which is similar but lacks sufficient detail and conciseness is described by Prelog, Frenkiel, Kobelt and Barman (62). The preparation of this compound was carried out as follows:

A 3-necked, 3-liter flask was fitted with a gas-inlet tube, a 2-bladed steel stirrer with mercury seal, and short, straight water-cooled condenser. The top of the condenser was coupled to a glass-stoppered introducing funnel by means of a straight vacuum adapter. In order to remove the last traces of oxygen (this was found to be of the utmost importance), the nitrogen was bubbled

through a tower containing an alkaline solution of 1,2,3-benzenetriol (pyrogallol) (88) followed by 2 drying towers containing calcium chloride and anhydrous aluminum oxide. Twelve hundred ml. of xylene which had been dried over anhydrous aluminum oxide and freshly distilled, was placed in the reaction flask. Approximately 200 ml. of this solvent was distilled over to remove the last traces of moisture that remained in the system. Nitrogen was run through the system overnight to remove oxygen from the apparatus. In the morning the xylene was heated to reflux temperature and the stirrer was started. Forty-six grams (2 moles) of freshly-cut sodium was added in small quantities by quickly removing and replacing the gas-inlet tube. One hundred fifteen grams of freshly distilled dimethyl ester of decanedioic acid (dimethyl sebacate) (0.5 mole) in 80 ml. of the purified xylene was placed in the introducing funnel and added dropwise at a constant rate over a period of 10 hours. The solution exhibited a red coloration toward the end of this addition. The reaction mixture was refluxed for an additional hour before it was cooled to room temperature by means of a water bath. Approximately 150 ml. of methanol was slowly added to decompose the remaining metallic sodium. The temperature of the solution was not allowed to exceed 40° during this period. The solution was allowed to stand overnight

to insure complete reaction of the sodium. Dilute sulfuric acid (3-4 normal) was slowly added until the aqueous phase was found to be acid. The mixture was removed from the nitrogen atmosphere and placed in a separatory funnel. The xylene layer was separated, washed with water, then with dilute sodium carbonate solution, again with water and placed to dry over anhydrous aluminum oxide.

The xylene was removed from this solution by distillation through a Vigreux column under reduced pressure. Twenty grams of cyclodecan-1-ol-2-one distilled as a yellow oil at 108-112° at 4-5 mm. The yield was 24 per cent based on the quantity of ester taken. The product was crystallized 3 times by dissolving it in petroleum ether (b.p. 60-70°) and then cooling the mixture in a dry-ice and acetone bath. The purified, light yellow product melted at 36°. Stoll, et al., reported 38-39° (75,76). Approximately 20 ml. of a brown liquid which solidified upon cooling remained in the distillation flask. This material was found to be mostly decanedioic acid. In previous runs in which the procedure of Prelog, et al., (62) was followed as closely as possible, the isolated products were largely this acid and only a small quantity of cyclodecan-1-ol-2-one. On the basis of later work the unproductiveness of these runs was attributed to the fact

that Prelog, et al., did not remove the last traces of oxygen from the nitrogen used. The amount of decanedioic acid produced served as a measure of the oxygen present during the cyclization.

Two independent procedures were employed for the oxidation of the cyclodecan-1-ol-2-one to 1,2-cyclodecane-dione. In the method of Prelog, et al., the acyloin is oxidized by chromium(VI) oxide in a glacial acetic acid solution. The dione is extracted from the reaction mixture with petroleum ether (b.p. 60-70°). After this extract is dried, the petroleum ether is allowed to evaporate off, leaving the yellow dione. Upon using this method 40 to 47 per cent yields of dione, m.p. 36°, were obtained. Prelog, et al., reported a melting point of 44°.

The other method was adapted as follows from a procedure of Weiss and Appel (95) which had been used for a similar type of oxidation:

One gram of cyclodecan-1-ol-2-one, 0.3 gram of ammonium nitrate, 10 ml. of 80 per cent acetic acid and 0.01 gram of copper(II) sulfate were placed in a small flask fitted with a reflux condenser. After 2.5 hours of refluxing the dione was extracted with petroleum ether (b.p. 60-70°). The product, m.p. 34°, was isolated as described above in a yield of 25 per cent (0.25 gram).

The following procedure was worked out for the oximation of 1,2-cyclodecanedione to 1,2-cyclodecanedionedioxime:

Four grams of the dione was added to 50 ml. of solution in a reflux apparatus containing 4.2 grams (0.06 mole) of hydroxylammonium chloride and 2.4 grams of sodium hydroxide (0.06 mole). The addition of 80 ml. of ethanol was required to dissolve the dione completely. The mixture was refluxed for 1 hour on a steam bath. The ethanol was removed by heating the solution in a beaker under an infrared lamp. The remaining solution was filtered, about 3.5 grams of a tarry mass being recovered. This material was dissolved in 25 ml. of boiling ethanol to which a small amount of norite was added. The crystals obtained upon cooling the filtrate were recrystallized twice from benzene, norite being used the first time. A yield of 0.8 gram of white crystals of 1,2-cyclodecanedionedioxime, m.p.  $184^{\circ}$ , was obtained. The nitrogen content of the product was determined (micro-Dumas); N calculated, 14.1 per cent; N found, 14.3, 14.4 per cent.

(b) A study of some of its properties. 1,2-Cyclodecanedionedioxime was found to react with nickel(II) and palladium(II) ions to produce orange-yellow and lemon-yellow precipitates respectively. The former reaction was found to be not quantitative after a reasonable length of

time at pH 4.5. Small weighed samples of the dioxime in ethanol were treated with large excesses of nickel(II) chloride solution. After 30 minutes of digestion the solutions were allowed to stand overnight before filtering. It was noted that a small amount of precipitation continued to take place in the filtrates, accounting for the fact that not quite all the dioxime was recovered as the nickel derivative of 1,2-cyclodecanedionedioxime. This incompleteness of reaction was also noted at pH 3.6.

The solubility of 1,2-cyclodecanedionedioxime in water was determined, however, by weighing the precipitate formed by nickel(II) ions with this vic-dioxime in a measured volume of solution saturated with the dioxime at 24°. It was realized that the result obtained, 0.099 gram or 0.005 mole per liter, was slightly low, but it was thought that this would be sufficiently accurate for the purpose of this particular investigation. Because of its unfavorable characteristics the properties of 1,2-cyclodecanedionedioxime were not studied further.

#### D. Conclusions and Summary

The preparation of 1,2-cyclopentanedione by the method of Riley, Morley and Friend and by a method adapted from that for the preparation of 1,2-cyclohexanedione has been



studied and found to yield only small quantities of product. It is thought that the low yields result from the instability of the intermediate organo-selenium compound undoubtedly involved in the selenium dioxide oxidation. A satisfactory method for the oxidation of this dione to 1,2-cyclopentanedionedioxime has been devised. This water-soluble vic-dioxime showed little or no promise as an analytical reagent because of the very narrow pH range over which the nickel compound is insoluble.

The use of 1,2-cyclohexanedionedioxime as a gravimetric and colorimetric analytical reagent for nickel(II) and palladium(II) ions has been studied and reported. Its general gravimetric use is more suited to the gravimetric determination of palladium, as no satisfactory method could be devised for the determination of nickel in the presence of appreciable amounts of iron. This 6 carbon vic-dioxime apparently forms a very stable complex with iron(II) and slowly reduces iron(III) to iron(II) in spite of the presence of strong complexing agents for the iron(III) ion. As a qualitative reagent for nickel, 1,2-cyclohexanedionedioxime apparently has no equal.

Syntheses of 1,2-cycloheptanedione and its dioxime that both gave high yields of product are described. Methods are presented for the macro- and micro-gravimetric

analyses of nickel, including nickel in steel, based on the use of this water-soluble vic-dioxime as the precipitant. This reagent, capable of precipitating nickel(II) ions from solutions containing large quantities of iron(III) complexed with tartrate or citrate, was found to possess almost all the good characteristics of both 2,3-butanedionedioxime and 1,2-cyclohexanedionedioxime without their disadvantages. Platinum interfered with the gravimetric determination of palladium with 1,2-cycloheptanedione-dioxime.

The Stoll, Hulstkamp and Rouvé method for the preparation of cyclodecan-1-ol-2-one was successfully carried out. Two methods were employed for the oxidation of this acyloin to the dione. A procedure for the oximation of this compound to 1,2-cyclodecanedionedioxime was devised. This reagent, insoluble in water, exhibited no value as an analytical reagent for nickel(II) or palladium(II) ions.

### III. PART TWO: INFRARED SPECTROSCOPIC STUDY OF THE NATURE OF THE HYDROGEN BOND IN THE INNER-COMPLEX COMPOUNDS

Infrared spectroscopy was selected for this study of the nature of the hydrogen bond in the nickel(II) and palladium(II) inner-complex compounds of several vic-dioximes because of the direct manner in which it has been possible to detect hydrogen bonds by this method. Literally hundreds of papers have appeared in the literature in which the influence of hydrogen bonding on specific absorption maxima has been recorded (4, 34, 35, 63). Infrared data on hydrogen bonds in organic and inorganic compounds and mixtures have been profuse. However, apparently very little attention has been paid to this type of investigation of inner-complex compounds.

#### A. Review of the Literature

The gross features of the structure of the inner-complex compounds formed by the reaction of the anti-form of vic-dioximes with nickel(II) and palladium(II) ions have been well established. Several publications (17,18,21) have served to review the gradual compiling of research results and conclusions that have led to our present knowledge of these metallo-organic molecules. The chronological course of this slow evolutionary development is not

restated at this time. Rather, the published evidence is presented according to its nature, i. e., knowledge of analogous compounds, steric considerations, magnetic measurements, X-ray examination and chemical evidence.

Pfeiffer and Richarz (61) and Pfeiffer (60) deduced the configuration of the nickel(II) derivatives of the vic-dioximes from a knowledge of analogous compounds. They had established the structure for the inner-complex compounds of nickel(II) and cobalt(II) with 1,2-diphenyl-ethanedionemonoxime on the basis that only the anti-form of this 1,2-diketonomoxime would react with these ions to form inner-complex compounds. Since the nickel-nitrogen linkage was well known in nickel amine coordination compounds, it was natural to postulate, in the case of the vic-dioximes, the 5-membered ring structure in which the central nickel atom is bonded directly to the 4 nitrogen atoms.

An important contribution to the proof of Pfeiffer's structure was made by Sugden (77), who prepared the nickel derivative of 1-phenyl-2,3-butanedionedioxime. By repeated crystallizations from acetone he was able to separate 2 isomeric compounds. These isomers, which were both shown to have empirical formulas corresponding to  $(C_{10}H_{11}O_2N_2)_2Ni$ , were found to have widely separated

melting points:  $\alpha$ -form,  $168^{\circ}$ ,  $\beta$ -form  $75-77^{\circ}$ . The parent dioximes regenerated from each of the  $\alpha$ -form

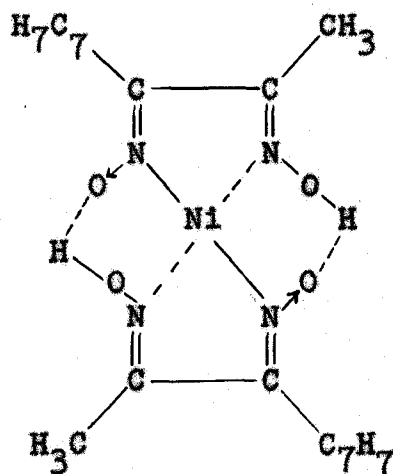

and the  $\beta$ -form

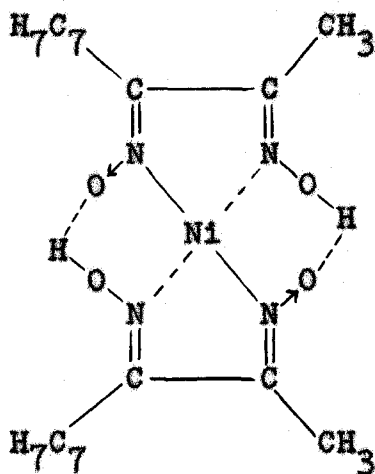

proved to be identical. Also, acetylation of both of these geometric isomers with acetic anhydride in the presence of pyridine gave the same diacetyl derivative which in turn was identical with that prepared directly from the parent

dioxime. These data showed that the same isomeric dioxime was present in each of the nickel derivatives.

Structural isomerism involving the displacement of a proton did not seem reasonable on the basis of the large difference in observed melting point of the 2 nickel derivatives. Two of the 4 possible isomers for the cis-compound are shown below.

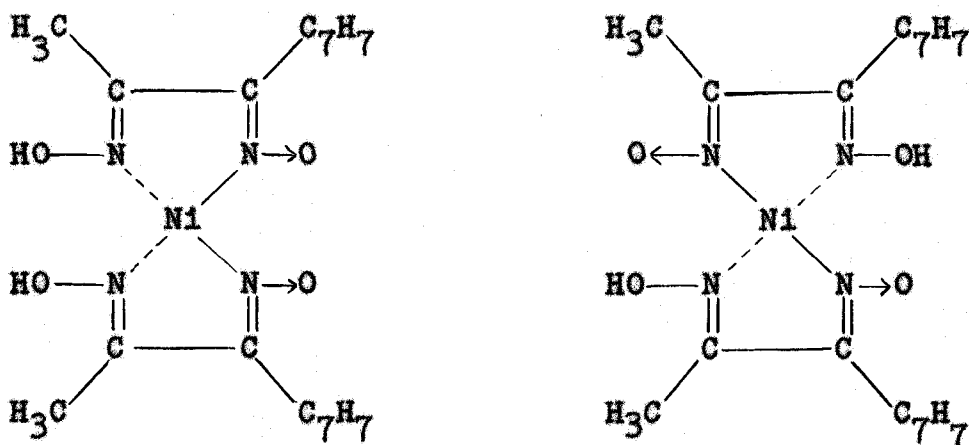

Similar isomerism involving the trans-form of this inner-complex compound also had been postulated.

The assignment of the trans-configuration to the higher melting isomer ( $\alpha$ -form) was made as a result of dipole moment measurements.

Cavell and Sugden (11) extended this work to include separations of the isomeric forms of the nickel inner-complex compounds of 1-methyl-2,3-hexanedionedioxime and 1-methyl-2,3-heptanedionedioxime.

Dwyer and Mellor (20) isolated 2 isomers of the palladium(II) derivative of 1-phenyl-2,3-butanedionedioxime. Their studies and conclusions were similar to those of Sugden and Cavell.

That the assignment of a planar structure to the nickel vic-dioxime inner-complex compounds was correct has received additional proof from magnetic susceptibility measurements. Nickel(II) ions upon forming  $dsp^2$  type bonds are diamagnetic since this ion's 8 unshared 3d electrons must form 4 pairs. Ample evidence has been reported to show that no unpaired electrons exist in these compounds and, thus, that they are of the square coplanar class. Cambi and Szegő<sup>"</sup> (10) and Klemm, Jacobi and Tilk (45) have shown that the nickel(II) derivatives of 2,3-butanedionedioxime and 1,2-diphenylethanedionedioxime are diamagnetic. Sugden (77) and Cavell and Sugden (11) found that the nickel complexes formed with 1-phenyl-2,3-butanedionedioxime, 1-methyl-2,3-hexanedionedioxime and 1-methyl-2,3-heptanedionedioxime (both the  $\alpha$ - and  $\beta$ -form in each case) are also diamagnetic. The same results were obtained for the solid nickel(II) derivative of 1-methyl-2,3-propanedionedioxime by Willis and Mellor (101). In pyridine solution, however, the complex was found to exhibit paramagnetism. The authors

suggested that the difference in stability of the square and tetrahedral complexes is so small that some of the molecules of the coplanar configuration are converted to the latter configuration under the influence of this solvent. Perhaps this conversion represents a correlation with the results found by Sugden as opposed to those of Barker (3) in regard to acetylating the complexes with acetic anhydride in the presence of pyridine or in anhydrous ether. It is to be noted, however, that different parent vic-dioximes were involved.

Mellor and Craig (53) prepared the nickel(II) complex of 1,2-napthoquinonedioxime and found this dark green amorphous compound was diamagnetic. Feigl (23) states that aromatic rings destroy the specific activity of vic-dioxime groups and that as parts of such compounds they behave as dibasic acids. This point needs clarification since Mellor and Craig have shown that their complex has an empirical formula,  $(C_{10}H_7O_2N_2)_2Ni$ . This would indicate the presence of the normal structure. That the vic-dioximes are not actually specific for nickel(II) and palladium(II) ions has been shown many times (17, p 42-46; 36, 51) 1,2-Bis-(2,3-butanedionedioximo-N,N')palladium(II) was observed to be diamagnetic by Janes (41).

X-ray analyses of the structure of the complexes formed between nickel(II) ions and 2,3-butanedionedioxime



and between nickel(II) ions and 2,3-pentanedionedioxime have been reported by Milone and Tappi (54,55). The results of their work, which by their own admission was incomplete and lacking in preciseness, indicated the general correctness of the structures proposed for this type inner-complex compound by Pfeiffer and later workers. Rundle and Godycki (71) are conducting X-ray structure determinations on 1,2-bis(2,3-butanedionedioximo-N,N')nickel(II). Their preliminary findings confirm the existence of a planar structure for these molecules and establish that the N-Ni-N bonds form approximately right angles. The Ni-Ni distance is observed to be 3.25 Å.

Chemical evidence indicating a lack of reactivity or, at least, greatly decreased reactivity of the hydrogen of the remaining hydroxyl groups of these inner-complex compounds has been recorded. Tschugaeff (83) reported early that these compounds would not react with phenyl isocyanate.

Barker (3) recorded that 1,2-bis(2,3-butanedionedioximo-N,N')nickel(II) was not acted upon by acetic anhydride in anhydrous ether solution. Under the same experimental conditions 2,3-butanedionedioxime is very readily acetylated, giving the diacetyl derivative. Barker also found that this complex compound formed addition products when treated with either methyl iodide or methyl sulfate under

anhydrous conditions. These compounds decomposed under the action of dry ammonia to yield the original 1,2-bis(2,3-butanedionedioximo-N,N')nickel(II) and methylammonium iodide and methylammonium sulfate, respectively. It is interesting to note that Barker, in order to account for his experimental results, suggested the following structural formula for the nickel derivative.

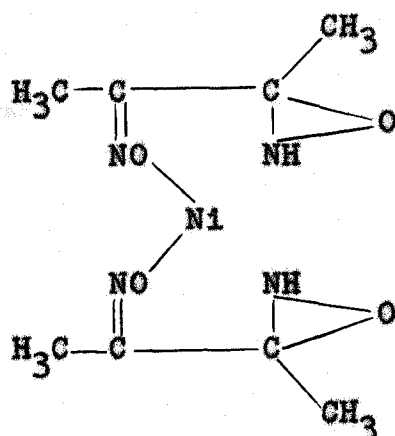

In the formation of the 2 addition compounds, the existence of a pentavalent state for the amino nitrogens was postulated. Also, Barker apparently ignored the possibility that the hydrogens attached to these nitrogens would be active, which could lead to the formation of an acetyl derivative under the experimental conditions employed.

Brady and Muers (6) found that 1,2-bis(2,3-butanedionedioximo-N,N')nickel(II) gave no methane with methylmagnesium iodide in amyl ether; that is, they obtained a

negative test for active hydrogens by the Zerewitinoff method.

Evidence that the acidity and, consequently, the reactivity of the oxime hydrogens have been greatly reduced upon forming an inner-complex compound with nickel(II) or palladium(II) ions lies in the fact that the vic-dioximes will dissolve in very dilute basic solutions while the inner-complex compounds will precipitate from strongly basic solutions upon the addition of the appropriate cations. Thus, the oxime hydrogens of these latter compounds cannot be regarded as being free of strong intramolecular actions.

These findings are not inconsistent with the work of Thilo and Friedrich (78) by which they prepared the compound  $\text{NaHNi}(\text{C}_4\text{H}_6\text{O}_2\text{N}_2)_2$  by treating 1,2-bis(2,3-butanedione-dioximo-N,N')nickel(II) with sodium ethoxide in absolute ethanol. This crystalline substance was easily decomposed by water. Feigl and Suter (25) found that 1,2-bis(2,3-butanedione-dioximo-N,N')palladium(II) functions as an acid and were able to isolate, among others, its potassium and barium salts from strongly basic solution. These salts are decomposed to the normal inner-complex compound by dilute acids. Feigl and Suter presented evidence to show that the 1,2-bis(2,3-butanedione-dioximo-N,N')palladium(II) in strongly basic solution acts as an inner-complex anion.

The importance of the role of the hydroxyl hydrogen of the second oxime group becomes apparent when the O-monomethyl-vic-dioximes are considered. These O-monomethyl ethers

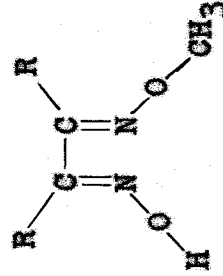

react with nickel(II) ions only under special conditions and the resulting complexes are relatively unstable (6,78).

Brady and Muers (6) were the first to suggest the presence of hydrogen bonds between the hydrogens of the hydroxyl groups and the proximate nitrene-form oxygens of the inner-complex compounds. The symmetry of the molecule and the relative chemical inertness of the hydroxyl hydrogens led them to this conclusion.

Published reports of infrared spectroscopic examinations of vic-dioximes have not been found. However, Buswell, Rodebush and Roy (8) conducted infrared absorption studies on several symmetrical monoketoximes, including the oxime of cyclohexanone, in carbon tetrachloride solution at varying concentrations. With low oxime concentrations they observed absorption maxima at about 2.76

microns, indicative of "free" O-H vibration frequencies. As the oxime concentrations were increased, the molal absorption due to "free" O-H decreased and absorption maxima at about 3.0 microns increased in molal absorption. The assignment of these latter maxima to intermolecularly associated O-H is consistent with the behavior expected of these groups in the more concentrated solutions.

Buswell, Dietz and Rodebush (7) were among the first to show that O-H absorption maxima are shifted to longer wave lengths with the formation of hydrogen bonds by the hydroxyl hydrogens. Badger (1) found that a definite relation existed between the energy of the hydrogen bond and the shift of the O-H absorption maxima which accompanies the formation of the hydrogen bond. The effect of this bond is to exert a restraining influence upon the O-H bond and thereby reduce its vibration frequency relative to the vibration frequency of the "free" O-H bond. The absorption maxima for the fundamental O-H vibration frequencies are found in the range of approximately 2.7 microns for "free" O-H groups and up to 4.0 microns for strongly associated O-H groups (65, p. 6). In this study, it was assumed that by observing the position of the O-H absorption maxima in the various nickel(II) and palladium(II)

vic-dioxime inner-complex compounds compared to those for "free" O-H absorption maxima at least a qualitative measure of the strength of the hydrogen bonds could be obtained.

#### B. Instruments

The spectra were recorded on a Baird Associates double-beam infrared recording spectrophotometer (Model B, serial 127). With this instrument the record of the infrared transmission is automatically obtained as an ink-drawn line on a paper chart graduated in per cent transmission as ordinate and in wave length as abscissa. To cover the range of the infrared spectrum from 2 to 16 microns a sodium chloride prism was employed. A potassium bromide prism was used for the range 12 to 26 microns. The wave length setting of the instrument was calibrated at frequent intervals by checking the positions of absorption maxima of known substances (polystyrene for the sodium chloride region and carbon dioxide for the potassium bromide region). Appropriate corrections were made. Specifications for this instrument claim an accuracy of  $\pm 0.02$  microns in the wave length setting and 1 per cent of the recorded value in per cent transmission.

Two window plates, one each of sodium chloride and potassium bromide, were available for the solid sampling.

The prepared window plate in its holder was placed in the undispersed radiation beam during the scanning process.

### C. Materials

1,2-Cyclohexanedionedioxime, 1,2-cycloheptanedionedioxime and 2,3-butanedionedioxime. The pure vic-dioximes were each recrystallized from benzene in order to remove last traces of water that might be present.

1,2-Cyclohexanedionedioxime- $d_2$ , 1,2-cycloheptanedionedioxime- $d_2$  and 2,3-butanedionedioxime- $d_2$ . These compounds were prepared in small quantities by recrystallizing the respective dried vic-dioximes from deuterium oxide (obtained through the Atomic Energy Commission from the Stuart Oxygen Company, San Francisco, California. Its purity was claimed to be 99.8 per cent). Approximately 150 ml. of deuterium oxide was required for the preparation of 200 mg. of 2,3-butanedionedioxime- $d_2$  because of its low temperature coefficient of solubility in this liquid. Fifteen to 20 ml. was sufficient for making the same amounts of the other deuterio vic-dioximes. All operations with deuterium oxide were carried out in a "dry-box" to prevent exchange with water in the laboratory atmosphere. Fresh portions of deuterium oxide were used for each individual operation in order to obtain a maximum degree of exchange

of deuterium for hydrogen. The crystals were dried by drawing warm, dry air over them for about 15 minutes and then placing them, spread out on filter paper, in a drying oven at 100-110° for a like period of time. These compounds, as well as the other vic-dioximes and derivatives, were stored in a desiccator.

1,2-Bis(1,2-cyclohexanedionedioximo-N,N')nickel(II),  
1,2-bis(1,2-cycloheptanedionedioximo-N,N')nickel(II) and  
1,2-bis(2,3-butanedionedioximo-N,N')nickel(II). These inner-complex compounds were precipitated by adding the reagent solutions to very dilute nickel(II) chloride solutions in a manner similar to that prescribed for the determination of nickel with the respective vic-dioximes. The precipitates were dried at 110° for 1 hour.

1,2-Bis(1,2-cyclohexanedionedioximo-d-N,N')nickel(II),  
1,2-bis(1,2-cycloheptanedionedioximo-d-N,N')nickel(II) and  
1,2-bis(2,3-butanedionedioximo-d-N,N')nickel(II). Anhydrous nickel(II) chloride was prepared by heating reagent-grade nickel(II) chloride 6-hydrate at 110° for several hours. For each compound a weighed amount of the anhydrous salt was dissolved in 30 ml. of deuterium oxide. A solution of a weighed quantity of the deuterio vic-dioxime in deuterium oxide was prepared (2 equivalents of the vic-dioxime for 1 of nickel(II) chloride). After the solutions



were heated to near boiling, the vic-dioxime solution was slowly added with stirring to the nickel(II) chloride solution. The solutions were digested for 10 minutes before filtration. The precipitates were dried at 110° for 1 hour.

In the case of 1,2-bis(2,3-butanedionedioximo-d-N,N')-nickel(II), it was necessary to add a small amount of reagent-grade anhydrous sodium carbonate to the reaction solution in order to raise the pH to a value where complete precipitation was obtained. Two hundred mg. of each compound was prepared.

1,2-Bis(1,2-cyclohexanedionedioximo-N,N')palladium(II), 1,2-bis(1,2-cycloheptanedionedioximo-N,N')palladium(II) and 1,2-bis(2,3-butanedionedioximo-N,N')palladium(II). These compounds were prepared in a manner similar to that employed for the corresponding nickel derivatives.

Nujol. Heavy Mineral Oil, U.S.P., obtained from Stanco Incorporated, Linden, New Jersey, was used.

Perfluorokerosene. DuPont perfluorokerosene FCX-330 was employed.

#### D. Experimental

The compounds derived from 2,3-butanedionedioxime were included in this investigation in order to be able to

compare the infrared spectra obtained for the 2 alicyclic vic-dioximes and their derivatives with corresponding compounds in which there were no alicyclic rings.

### 1. Methods

The various vic-dioximes and inner-complex compounds were prepared for infrared examination by the mull technique. Each sample (approximately 20 mg.) was ground in a few drops of Nujol or perfluorokerosene in a small agate mortar. It was necessary to grind the parent compounds much more extensively than the inner-complex derivatives because of the tendency of the vic-dioxime crystals to scatter the infrared radiation. The paste was spread to the desired thickness on a window-plate of the same composition as the prism. No reference window-plate was used with this technique. When thick pastes were necessary in order to bring out weak absorption bands, compensation for the loss in transmitted radiation of the sample beam was obtained by closing down the shutter in front of the reference beam, which had the effect of increasing the difference in radiation energy between the 2 beams.

The mull technique was employed for this investigation since suitable solvents for the various compounds were not found. Solvents such as pyridine, which dissolve the inner-complex compounds, were known to change the identity

of these compounds (101). Because of the nature of the work, such structural alterations could not be tolerated.

Non-polar solvents could not be found that would dissolve enough of either the parent vic-dioximes or the derivatives to permit the successful application of liquid sampling.

Perfluorokerosene was employed in addition to Nujol for the preparation of the mulls because it gives rise to no absorption maxima in the region of 2 to 7 microns. Thus, it does not preclude sample data in this region at the wave lengths where the Nujol C-H absorption maxima occur.

## 2. Results

The individual infrared absorption spectra of 1,2-cyclohexanedionedioxime, 1,2-cycloheptanedionedioxime and 2,3-butanedionedioxime in Nujol in both the sodium chloride and potassium bromide regions are shown in Figures 1 through 6 (curve "A" in each figure). Strong absorption maxima for C-H vibrations of Nujol are observed at 3.41, 6.84 and 7.27 microns (65, p. 201). Weak absorption maxima (or minima) occurring at approximately 2.5 and 4.3 microns in some of these spectrograms are apparently due to the presence of carbon dioxide (44). An absorption maximum

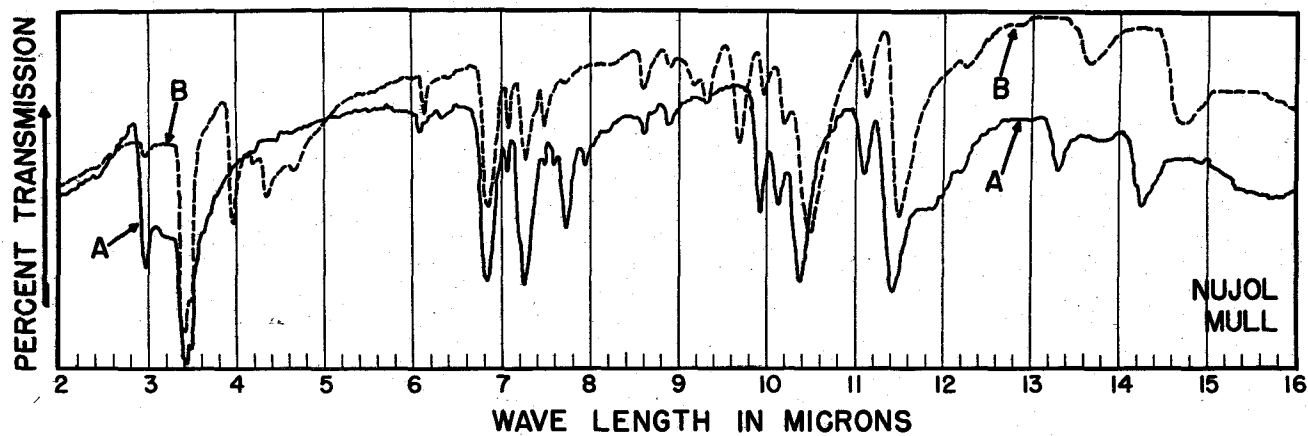

Fig. 1—Infrared Absorption Spectra of  
 (A) 1,2-Cyclohexanedionedioxime  
 (B) 1,2-Cyclohexanedionedioxime - $d_2$

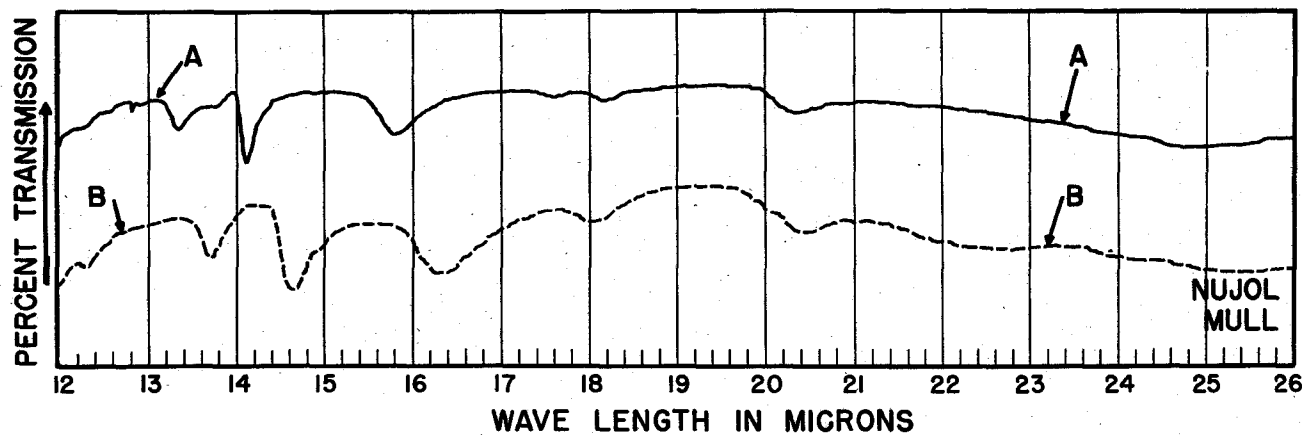

Fig. 2—Infrared Absorption Spectra of  
 (A) 1,2-Cyclohexanedionedioxime  
 (B) 1,2-Cyclohexanedionedioxime - $d_2$

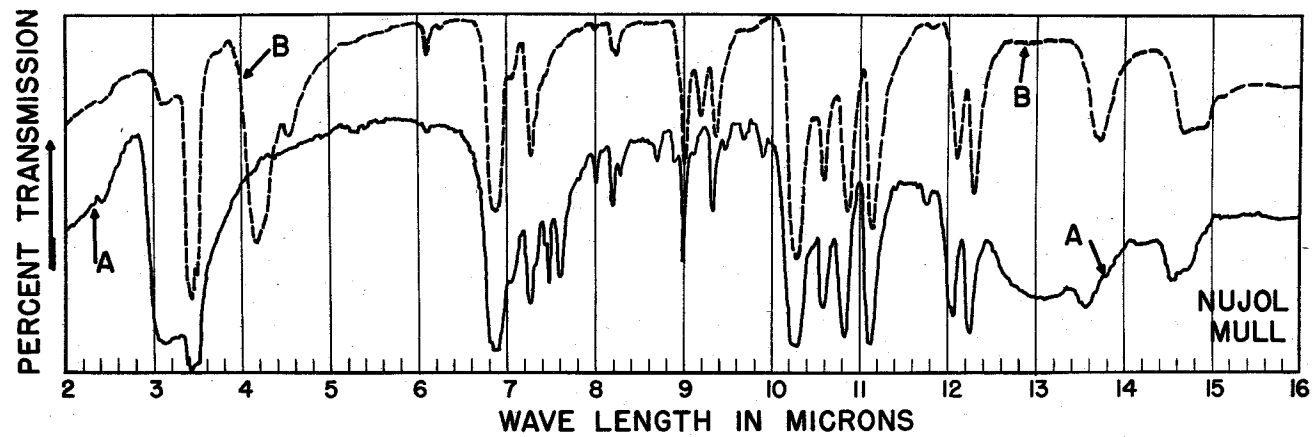

Fig.3-Infrared Absorption Spectra of  
 (A) 1,2-Cycloheptanedionedioxime  
 (B) 1,2-Cycloheptanedionedioxime- $d_2$

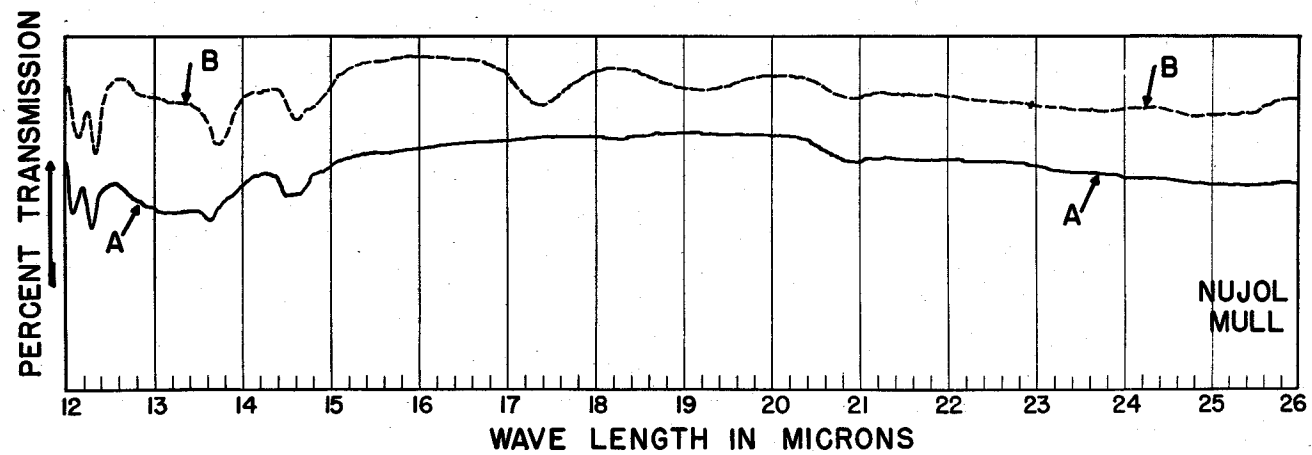

Fig.4-Infrared Absorption Spectra of  
 (A) 1,2-Cycloheptanedionedioxime  
 (B) 1,2-Cycloheptanedionedioxime- $d_2$

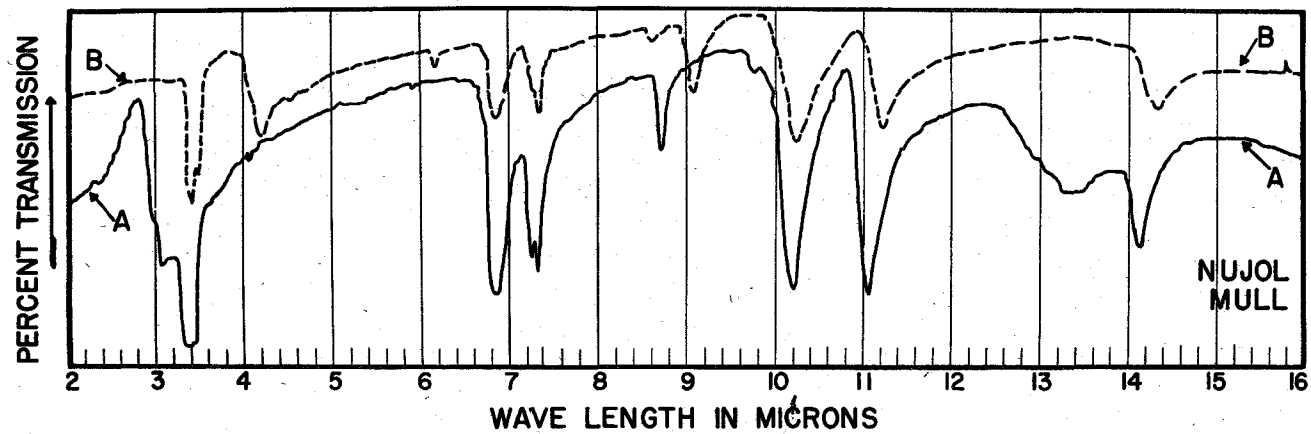

Fig.5-Infrared Absorption Spectra of  
 (A) 2,3-Butanedionedioxime  
 (B) 2,3-Butanedionedioxime -d<sub>2</sub>

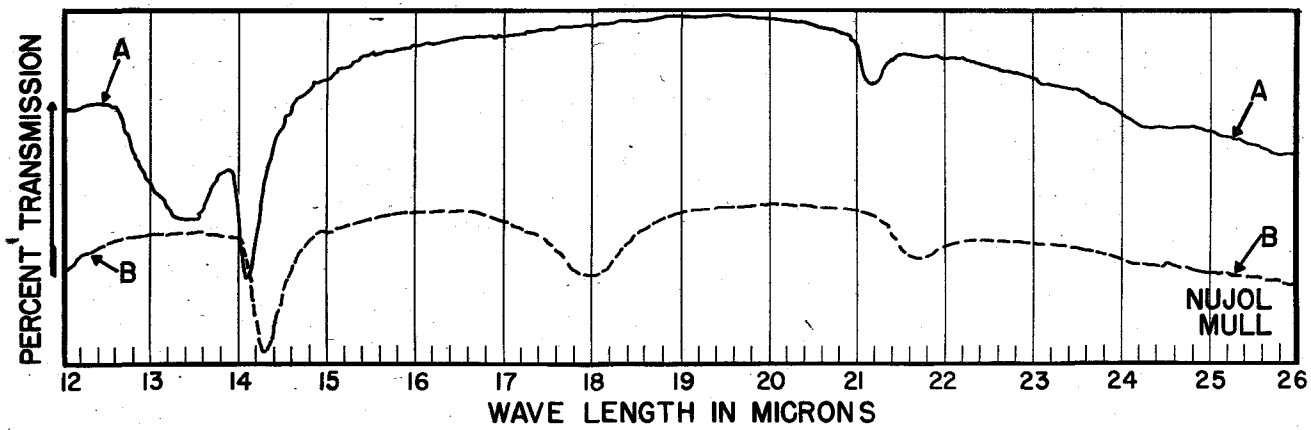
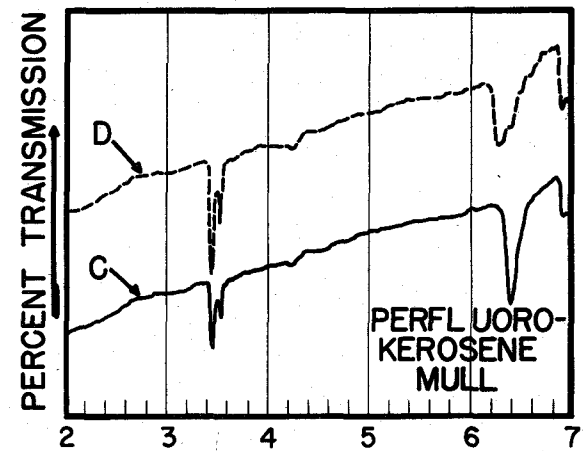
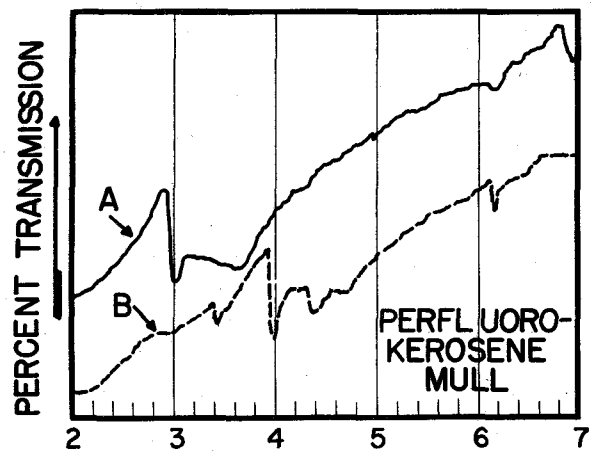

Fig.6-Infrared Absorption Spectra of  
 (A) 2,3-Butanedionedioxime  
 (B) 2,3-Butanedionedioxime -d<sub>2</sub>

for the vic-dioxime O-H groups in 1,2-cyclohexanedione-dioxime is observed at 2.98 microns (sodium chloride region). For 1,2-cycloheptanedione-dioxime and 2,3-butanedione-dioxime these maxima are observed at 3.11 and 3.13 microns, respectively. Each absorption maximum appeared to be fairly strong. The absorption spectra of these 3 compounds in perfluorokerosene in the range of 2 to 7 microns are shown in Figures 7, 8 and 9, respectively (curve "A" in each case). The O-H absorption maxima are found at wave length values agreeing, within the limits of accuracy of the instrument, with those observed with the same compounds in Nujol mulls. A C-H absorption maximum (3.41 microns) was well defined only in the case of 1,2-cycloheptanedione-dioxime, appeared very broad in 1,2-cyclohexanedione-dioxime and was not noticeable in 2,3-butanedione-dioxime.

No attempt was made to assign all the absorption maxima observed, as this task would have been extremely difficult and, in view of the great degree of uncertainty that would accompany such an effort, very unrewarding. Also, from the stated purpose of this investigation it seemed permissible to limit the assignment of absorption maxima to those vibration frequencies which could be identified with a reasonable surety and which would yield specific information concerning the nature of the O-H



WAVE LENGTH IN MICRONS

Fig.7—Infrared Absorption Spectra of

- (A) 1,2 - Cyclohexanedionedioxime
- (B) 1,2 - Cyclohexanedionedioxime -  $d_2$
- (C) 1,2 - Bis (1,2-cyclohexanedionedioximo- $\underline{N,N'}$ ) nickel (II)
- (D) 1,2 - Bis (1,2-cyclohexanedionedioximo- $\underline{d-N,N'}$ ) nickel(II)



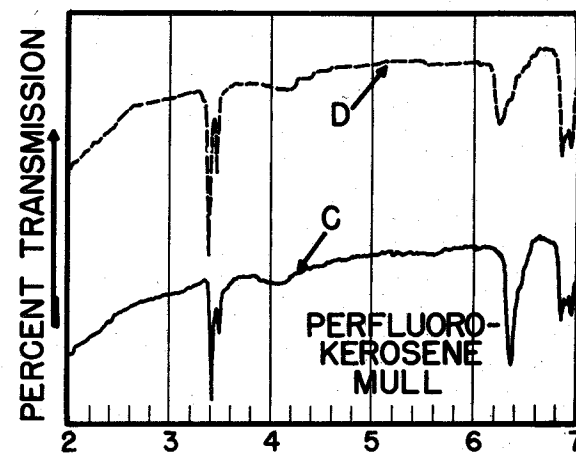
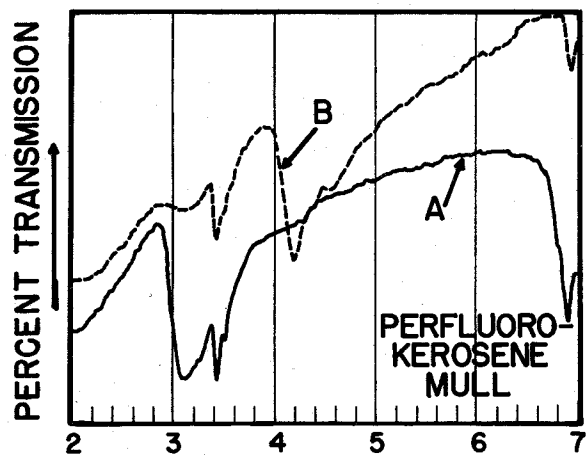

WAVE LENGTH IN MICRONS

Fig.8—Infrared Absorption Spectra of

- (A) 1,2-Cycloheptanedionedioxime
- (B) 1,2-Cycloheptanedionedioxime- $d_2$
- (C) 1,2-Bis(1,2-cycloheptanedionedioximo- $\underline{N}, \underline{N}'$ )nickel (II)
- (D) 1,2-Bis(1,2-cycloheptanedionedioximo- $\underline{d}-\underline{N}, \underline{N}'$ )nickel (II)

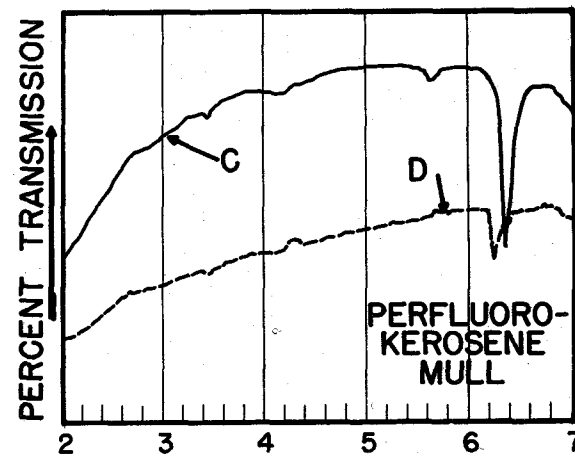
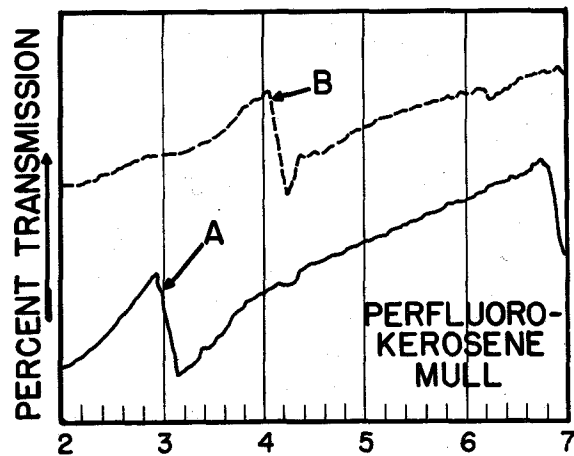

WAVE LENGTH IN MICRONS

Fig.9—Infrared Absorption Spectra of

- (A) 2,3-Butanedionedioxime
- (B) 2,3-Butanedionedioxime- $d_2$
- (C) 1,2-Bis(2,3-butanedionedioximo- $\underline{N}, \underline{N}'$ ) nickel (II)
- (D) 1,2-Bis(2,3-butanedionedioximo- $\underline{d}-\underline{N}, \underline{N}'$ ) nickel (II)

groups in the parent vic-dioximes and inner-complex compounds under consideration.

In Figures 1 through 6 ("B" curves) are shown the spectra of 1,2-cyclohexanedionioxime-d<sub>2</sub>, 1,2-cycloheptanedionioxime-d<sub>2</sub> and 2,3-butanedionioxime-d<sub>2</sub> in Nujol. The strong absorption maxima appearing at 3.99, 4.18 and 4.19 microns, respectively, were assigned to O-D vibration frequencies. As with the parent vic-dioximes, the O-D absorption maximum for 1,2-cyclohexanedionioxime-d<sub>2</sub> appeared sharper and at a slightly lower wave length than in the other 2 compounds.

It was felt that a comparison of the relative intensities of the O-H and O-D absorption maxima in these compounds would allow a quantitative estimation of the degree of the exchange of deuterium for hydrogen effected by the treatment with deuterium oxide. The 2 alicyclic compounds exhibited only relatively weak O-H absorption maxima at the previously observed wave lengths. The 2,3-butanedionioxime-d<sub>2</sub> showed no appreciable O-H absorption maxima. On the basis of these observations, the compounds were considered acceptable for their intended purposes.

It is to be noted that in 1,2-cycloheptanedionioxime-d<sub>2</sub> and 2,3-butanedionioxime-d<sub>2</sub> weak absorption maxima are found at 4.53 and 4.54 microns, respectively.

It is believed that these absorption maxima arise from C-D vibration frequencies indicating that an exchange of deuterium for hydrogen attached to carbon had taken place. In 1,2-cyclohexanedionedioxime-d<sub>2</sub> no well-defined absorption maximum is observed at these wave lengths; however, an absorption maximum at 4.39 microns and a weaker absorption maximum at 4.69 microns were found. The author does not feel justified in definitely assigning either of these maxima to C-D vibration frequencies. The apparent presence of C-D bonds was not considered detrimental in view of the purpose of these studies.

The absorption spectra of these 3 compounds in perfluorokerosene are shown as the "B" curves in Figures 7, 8 and 9. Data analogous to that with the Nujol mulls were found and weak O-H absorption maxima were observed. Again, the alicyclic members exhibited C-H absorption maxima but 2,3-butanedionedioxime did not. A very weak absorption maximum, appearing more as a shoulder on a stronger absorption maximum, was observed at 4.53 microns in 1,2-cyclohexanedionedioxime-d<sub>2</sub>.

The absorption spectra of the nickel(II) derivatives of 1,2-cyclohexanedionedioxime, 1,2-cycloheptanedionedioxime and 2,3-butanedionedioxime in Nujol (the "A" curves in Figures 10, 12 and 14) did not exhibit absorption

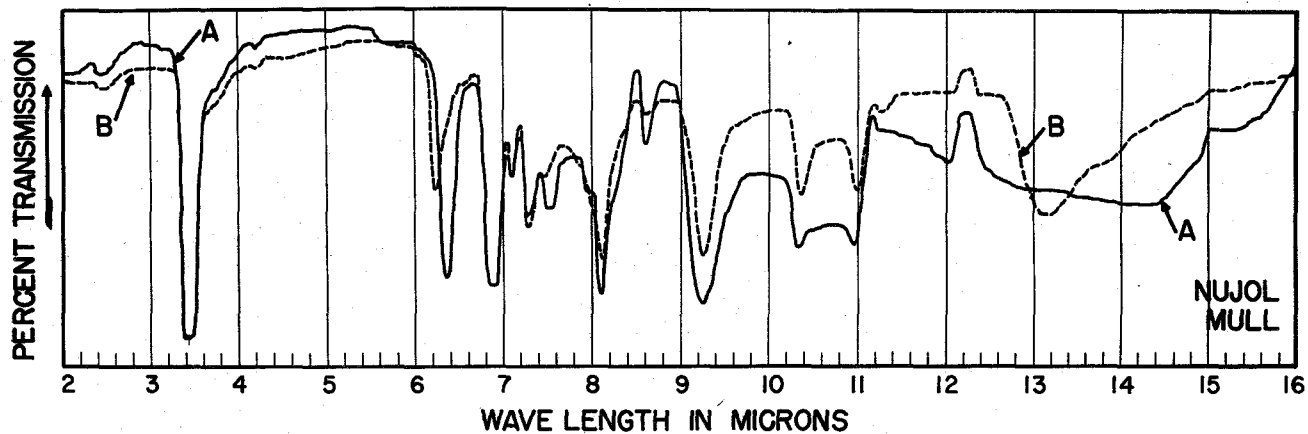

Fig.10-Infrared Absorption Spectra of

- (A) 1,2-Bis(1,2-cyclohexanedionedioxi-N,N')nickel (II)
- (B) 1,2-Bis(1,2-cyclohexanedionedioxi-d-N,N')nickel (II)

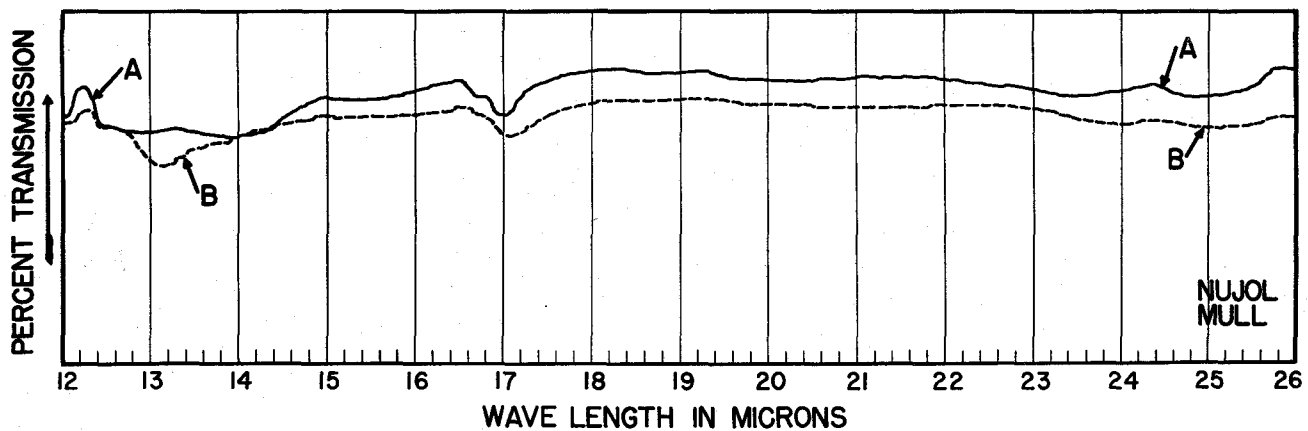

Fig.11-Infrared Absorption Spectra of

- (A) 1,2-Bis(1,2-cyclohexanedionedioxi-N,N')nickel (II)
- (B) 1,2-Bis(1,2-cyclohexanedionedioxi-d-N,N')nickel (II)

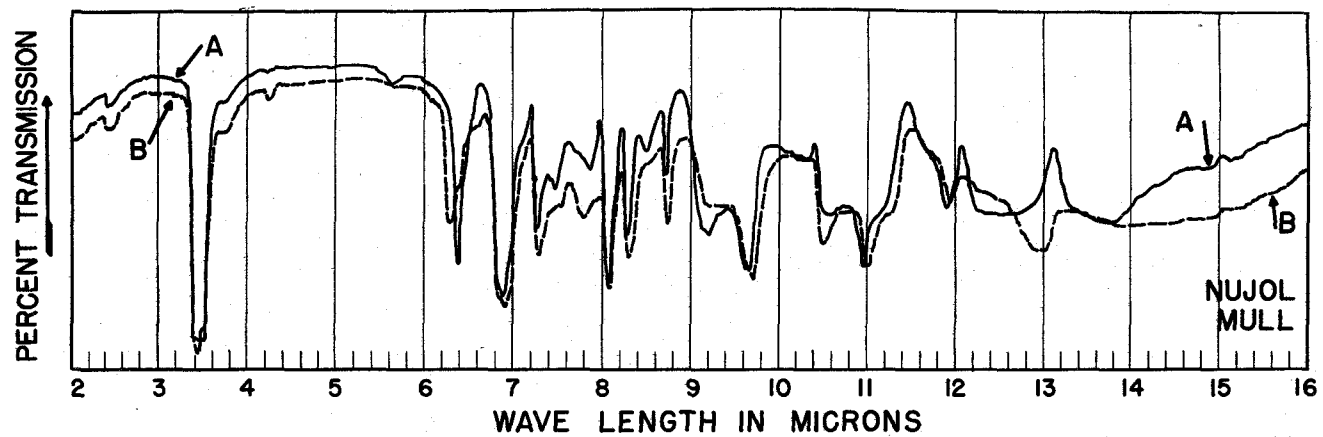

Fig.12—Infrared Absorption Spectra of  
 (A) 1,2-Bis(1,2-cycloheptanedionedioximo-N,N')nickel (II)  
 (B) 1,2-Bis(1,2-cycloheptanedionedioximo-d-N,N')nickel (II)

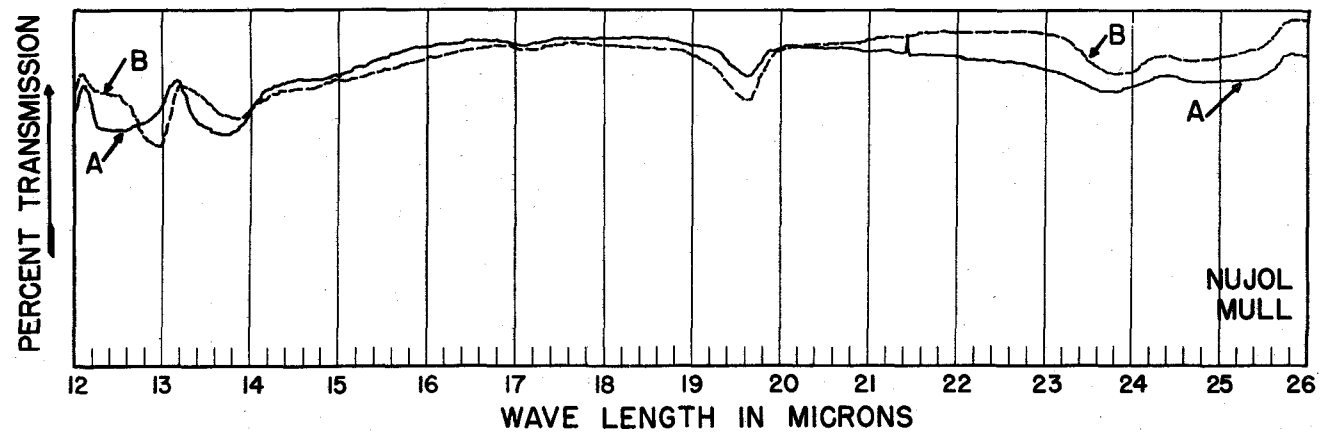

Fig.13—Infrared Absorption Spectra of  
 (A) 1,2-Bis(1,2-cycloheptanedionedioximo-N,N')nickel (II)  
 (B) 1,2-Bis(1,2-cycloheptanedionedioximo-d-N,N')nickel (II)

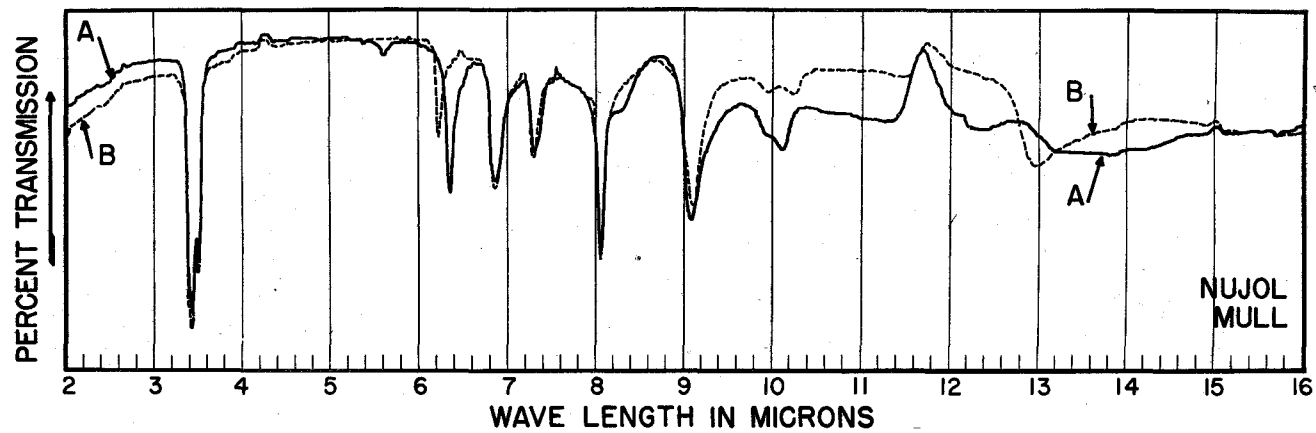

Fig.14-Infrared Absorption Spectra of  
 (A) 1,2-Bis (2,3-butanedionedioximo-N,N') nickel (II)  
 (B) 1,2-Bis (2,3-butanedionedioximo-d-N,N') nickel (II)

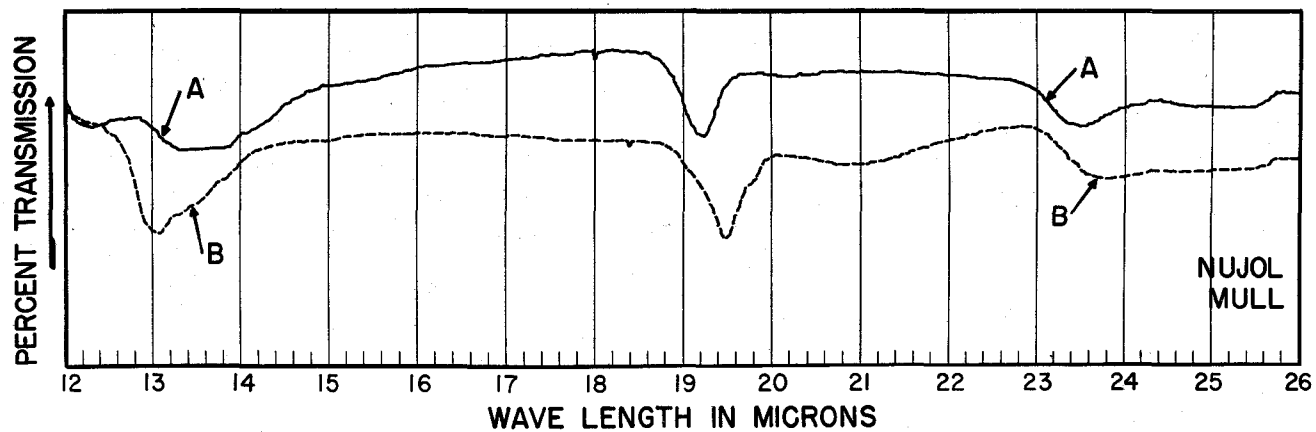

Fig.15-Infrared Absorption Spectra of  
 (A) 1,2-Bis (2,3-butanedionedioximo-N,N') nickel (II)  
 (B) 1,2-Bis (2,3-butanedionedioximo-d-N,N') nickel (II)

maxima that could be assigned to O-H vibration frequencies in the region in which these maxima normally occur. The same observation was made for these inner-complex compounds in perfluorokerosene (the "C" curves in Figures 7, 8 and 9).

The palladium(II) derivatives of these 3 vic-dioximes in Nujol mulls also failed to exhibit characteristic O-H absorption maxima, as is evidenced by their absorption spectra in Figures 16 and 17.

The infrared spectra of the nickel(II) inner-complex compounds of 1,2-cyclohexanedionedioxime- $\underline{d}_2$ , 1,2-cycloheptanedionedioxime- $\underline{d}_2$  and 2,3-butanedionedioxime- $\underline{d}_2$  in Nujol in the sodium chloride and potassium bromide regions are shown in Figures 10 through 15 ("B" curves in each case). Figures 7, 8 and 9 ("D" curves) show the spectral records of these compounds in perfluorokerosene in the range of 2 to 7 microns. Again, these spectra did not produce absorption maxima for O-D vibration frequencies in the usual wave length region. Another purpose of obtaining the spectra of the deuterio inner-complex compounds was to assist in the possible location of any absorption maxima attributed to O-H vibrations. It was assumed that any shift of absorption maxima that occurred between the normal inner-complex compounds and the deuterio inner-complex



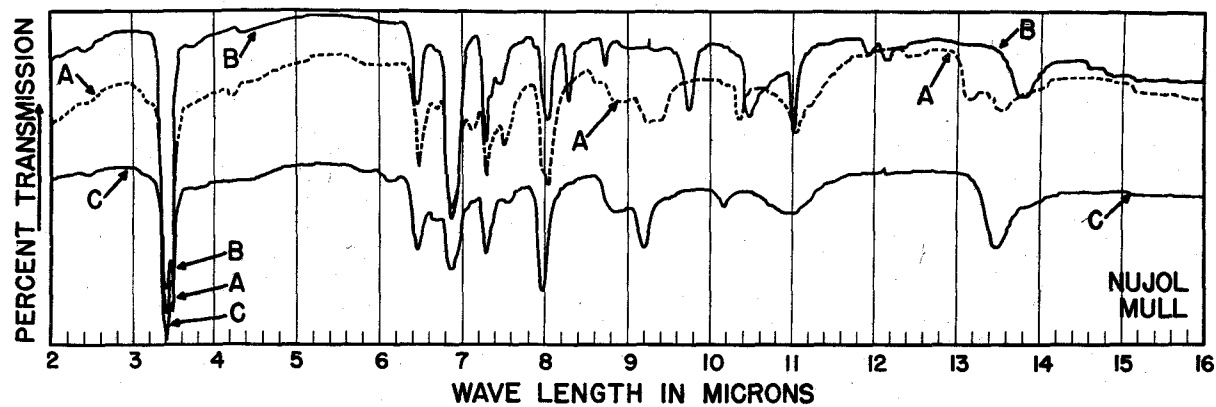

Fig. 16. Infrared Absorption Spectra of

- (A) 1,2- Bis(1,2-cyclohexanedionedioximo- $\underline{N}, \underline{N}'$ ) palladium (II)
- (B) 1,2- Bis(1,2-cycloheptanedionedioximo- $\underline{N}, \underline{N}'$ ) palladium (II)
- (C) 1,2- Bis(2,3-butanedionedioximo- $\underline{N}, \underline{N}'$ ) palladium (II)

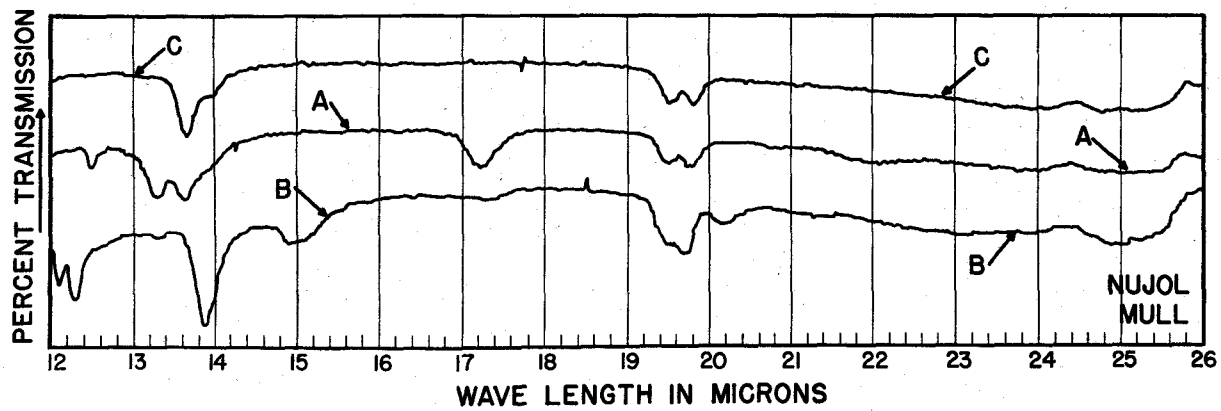

Fig. 17. Infrared Absorption Spectra of

- (A) 1,2- Bis(1,2-cyclohexanedionedioximo- $\underline{N}, \underline{N}'$ ) palladium (I)
- (B) 1,2- Bis(1,2-cycloheptanedionedioximo- $\underline{N}, \underline{N}'$ ) palladium (I)
- (C) 1,2- Bis(2,3-butanedionedioximo- $\underline{N}, \underline{N}'$ ) palladium (I)

compounds would indicate that the shifted absorption maxima arose from vibrations involving the oxime hydrogen or deuterium atoms. The apparent presence of C-D absorption maxima in the latter compounds must, of course, be recognized. It was further assumed that only shifts that were common to the spectra of each of the 3 pairs of compounds would be of value in drawing conclusions as to the possible disposition of the O-H absorption maxima.

Comparison of the 3 pairs of curves revealed that several consistent differences existed. In the Nujol mulls weak absorption maxima were found at 5.68, 5.61 and 5.62 microns, respectively, for the nickel(II) derivatives of 1,2-cyclohexanedioxime, 1,2-cycloheptanedioxime and 2,3-butanedioxime. In each of the nickel(II) derivatives of the deuterio compounds these maxima do not appear. Only in the case of 1,2-bis(2,3-butanedioximo-N,N')nickel(II) and its deuterio derivative is this phenomenon noted in the perfluorokerosene mulls.

Strong absorption maxima that occur at 6.38, 6.38 and 6.37 microns, respectively, in 1,2-bis(1,2-cyclohexanedioximo-N,N')nickel(II), 1,2-bis(1,2-cycloheptanedioximo-N,N')nickel(II) and 1,2-bis(2,3-butanedioximo-N,N')nickel(II) in both Nujol and perfluorokerosene appear to be shifted to the lower wave lengths of 6.25, 6.27 and

6.24 microns in the respective deuterio compounds, with an accompanying decrease in intensity.

The third and last consistent difference involved the strong, broad absorption maxima appearing in Nujol mulls in the sodium chloride region at 13.2 microns in 1,2-bis-(1,2-cyclohexanedionedioximo-d-N,N')nickel(II) and at 13.0 microns in the other 2 deuterio compounds. Absorption maxima are not exhibited at these wave lengths in the normal compounds. The curves for these compounds in Nujol mulls with the potassium bromide prism and window plate in this wave length region are the same as those observed above for each compound, except that the maxima are shifted slightly because of the experimental error apparently caused by the change in prisms.

#### E. Discussion

The absorption maxima attributed to fundamental O-H stretching vibration frequencies in the 3 vic-dioximes studied are found at wave lengths which are indicative of intermolecular association due to hydrogen bonding. The same observations are made for the fundamental O-D absorption maxima in the 3 respective deuterio compounds. That the assignment was correct is further substantiated by the fact that the presumed O-D maxima occur at wave lengths

that closely approximate the product of

$$\sqrt{\frac{\mu_{O-D}}{\mu_{O-H}}}$$

and the numerical values of the observed wave length for the respective O-H absorption maxima. The term

$$\sqrt{\frac{\mu_{O-D}}{\mu_{O-H}}}$$

results from assuming that the stretching vibrations of the O-H and O-D groups obey Hooke's law and that the motions described are similar to those observed for simple harmonic vibrations (5). In this approximation

$$\nu = \frac{1}{2\pi c} \sqrt{\frac{k}{\mu}}$$

where  $\nu$  is the frequency of vibration in  $\text{cm.}^{-1}$ ,  $c$  is the velocity of light,  $\mu$  is the reduced mass of the vibrating atomic pair and  $k$  is the force constant which exists between the atoms. The reduced mass for the O-H pair is 0.94 and for the O-D pair  $\mu_{O-D} = 1.78$ . Thus

$$\sqrt{\frac{\mu_{O-D}}{\mu_{O-H}}}$$

equals 1.37. The observed positions of the O-D absorption maxima, compared to those calculated by the relationship

$$\lambda_{\text{O-D}} \text{ (calculated)} = 1.37 \lambda_{\text{O-H}} \text{ (observed)}$$

are shown in Table 7. For the purpose of these approximate calculations the force constants were considered to be equal for these 2 atomic pairs.

On the basis of these data, it is not possible to state whether the hydrogen bonding is to oxygen or nitrogen (O-H---O or O-H---N) of another vic-dioxime molecule.

The absence in the usual wave length regions of absorption maxima that can be attributed to fundamental O-H and O-D stretching vibration frequencies in the respective inner-complex compounds indicates that the vic-dioxime O-H or O-D groups have greatly changed their identity upon forming the inner-complex compounds with nickel(II) and palladium(II) ions. If normal hydrogen bonding existed, as originally suggested by Brady and Muers, the respective absorption maxima should be observed. The presence of strong absorption maxima (other than from Nujol) in these spectrograms was an assurance that the mulls contained sufficient amounts of the inner-complex compounds to yield any possible O-H or O-D maxima in the normal wave length regions.

In normal OHO hydrogen bonds the O-H---O distances vary between about 2.5 and 2.9 Å (57, p. 289). The

Table 7  
Comparison of Positions of Observed and Calculated  
O-D Absorption Maxima

Parent <u>vic-dioxime</u>	Observed $\lambda$ O-H microns	Observed $\lambda$ O-D microns	Calculated $\lambda$ O-D microns
1,2-Cyclohexanedionedioxime	2.98	3.99	4.08
1,2-Cycloheptanedionedioxime	3.11	4.18	4.26
2,3-Butanedionedioxime	3.13	4.19	4.29

equilibrium position of the hydrogen atom from 1 oxygen atom is approximately  $1.0 \text{ \AA}$ , and from the other, between  $1.5$  and  $1.9 \text{ \AA}$ . Pauling (57, p. 311) has stated that  $2.54 \text{ \AA}$  was the smallest O-H---O bond distance known. No subsequent reports in the literature have been found that would invalidate this statement.

Since O-H absorption maxima are observed in cases of normal hydrogen bonding, the question arises as to the nature of the O-H groups in these inner-complex compounds. If the O-H---O distance in these compounds is greater than  $2.5 \text{ \AA}$  it appears reasonable to expect the O-H absorption maxima to be present in the usual wave length regions. An O-H---O distance greater than that normally assigned in hydrogen bonding should give rise to O-H absorption maxima characteristic of "free" O-H groups. The logical alternative involves the possibility that this distance is somewhat less than  $2.5 \text{ \AA}$ . The infrared spectroscopic evidence coupled with the chemical evidence for the lack of reactivity of the O-H hydrogens suggests the presence of an O-H-O structure unlike that observed in normal hydrogen bonding involving these atoms.

It is of interest to examine the studies of Westrum and Pitzer (99) on the nature of the hydrogen bond in crystalline potassium hydrogen fluoride. While there is

little in common between these ionic crystals and the nickel(II) and palladium(II) inner-complex compounds, the current knowledge of the F-H-F bonds may provide valuable information concerning the character of O-H-O bonds in the latter compounds. Infrared absorption maxima arising from "free" F-H fundamental vibration frequencies occur at approximately 2.4 microns and from F-H fundamental vibration frequencies in  $(\text{HF})_n$  polymers at approximately 2.9 microns. In these polymers the F-H---F distance has been determined to be about  $2.55 \text{ \AA}$  (99). However, in the potassium hydrogen fluoride crystals this distance is very close to  $2.26 \text{ \AA}$ . Ketelaar (44) obtained infrared spectral data for these crystals as well as for potassium deuterium fluoride. A strong absorption maximum at 6.9 microns has been attributed to the F-H fundamental stretching vibration frequencies indicating a considerable shift from the position of the maxima observed in the common H-F---H hydrogen bonds. An absorption maximum at 9.6 microns was assigned to the corresponding F-D vibration frequencies. These assignments were made by comparing the intensities of the corresponding reflection and absorption maxima.

Westrum and Pitzer have established on the basis of extensive thermodynamic data that potassium hydrogen fluoride reaches zero entropy if cooled to  $0^\circ \text{ K}$  and, thus,



does not contain residual randomness. A low dielectric constant, practically independent of temperature, also suggested the possibility of a symmetrical F-H-F arrangement. From these thermodynamic, spectral and dielectric data they have deduced that the potential curve for the proton in the  $\left[ \text{F-H-F} \right]$  ion has a single minimum located midway between the 2 fluoride atoms. Calculations of the "hydrogen bond" energy in F-H-F (14,44) have yielded values ranging from 30 to 50 kcal. per mole. Normal hydrogen bond energy values usually lie in the range of 4 to 8 kcal. per mole (57, p. 333).

The possibility of an O-H-O bond in the inner-complex compounds which has the same general characteristics as the F-H-F bond in potassium hydrogen fluoride crystals does not seem unreasonable in view of the evidence for the chemical unreactivity of the O-H hydrogens, the symmetry of the molecules and the spectral data presented herein. While 3 consistent maxima shifts have been detected, it appears unwise at this time to make definite statements concerning the possible disposition of any absorption maxima due to O-H and O-D fundamental vibration frequencies. It is entirely possible that these maxima shifts are not consistent for the 3 pairs and that each pair would have to be considered separately. When the O-H-O distances for 1 or more of these inner-complex compounds is known accurately it may be possible to calculate roughly the

expected positions of these absorption maxima (99).

Indications are, however, that the strong absorption maxima occurring at approximately 6.3 microns in each of the inner-complex compounds arise from C=N vibration frequencies. Absorption maxima of consistently less intensity are noted for the various parent vic-dioximes at about 6.2 microns, which is in the region normally attributed to C=N vibration frequencies (65, p. 30). Upon forming the inner-complex compounds, the C=N pair undoubtedly undergoes a change in its dipole moment which would lead to a variation in absorption intensity. Slight alterations in the orientation of this bonded atomic pair could accompany the formation of the new bonds and result in the slight shift in wave length of the absorption maxima. A reasonable explanation for the small shift of these absorption maxima caused by the introduction of deuterium in place of hydrogen in the inner-complex compounds could not be found.

In consideration of the data presented concerning the possible nature of the hydrogen bond in the inner-complex compounds formed by the reaction of nickel(II) ions with these vic-dioximes, the following atomic configuration

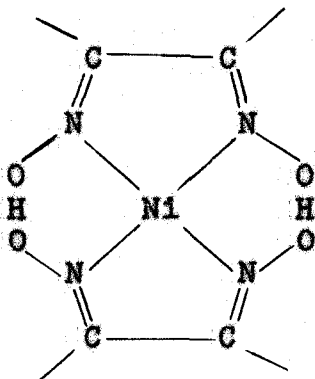

appears possible. In normal O-H---O hydrogen bond structures the hydrogen atom with its 1 stable orbital forms a covalent bond to the closer oxygen atom and a bond that is largely ionic in character to the other oxygen atom (57, p. 284). If this postulated atomic configuration is correct and the proton is located symmetrically between the 2 oxygen atoms that are less than  $2.5 \text{ \AA}$  apart, ionic bonding probably predominates in the O-H-O structure. The proton would act to balance the repulsive force between the 2 negative oxygens. One would, of course, expect the minimum O-H-O distance to be somewhat greater than twice the normal covalent O-H bond distance of  $0.96 \text{ \AA}$  (32). Presumably, the palladium(II) inner-complex compounds would have a similar atomic configuration.

#### F. Summary

1,2-Cyclohexanedionedioxime- $d_2$ , 1,2-cycloheptanedionedioxime- $d_2$  and 2,3-butanedionedioxime- $d_2$ , as well as their nickel(II) derivatives, have been prepared. The infrared

absorption spectra of these compounds, together with those of the parent vic-dioximes and their nickel(II) and palladium(II) derivatives, in Nujol mulls (range 2 to 26 microns) and perfluorokerosene mulls (range 2 to 7 microns) are presented.

The infrared spectra of the vic-dioximes and deuterio derivatives are considered, with particular emphasis on the O-H and O-D absorption maxima. The absence of O-H or O-D absorption maxima in the wave length regions usually attributed to vibration frequencies of these atomic pairs in the various inner-complex compounds is discussed. A comparison is made between the spectra of the 3 pairs of nickel(II) inner-complex compounds which differ only by the substitution of deuterium for hydrogen.

Arguments are presented for the possibility of an atomic arrangement of 1,2-bis(vic-dioximo-N,N')nickel(II) compounds in which the oxime hydrogens are located midway between the 2 oxygen atoms. An O-H-O structure in these compounds in which the oxygen to oxygen distance is less than 2.5 Å, is postulated.

#### IV. SUGGESTIONS FOR FUTURE WORK

Various studies could be made that might provide substantial knowledge concerning the importance of the proton in the proposed O-H-O bond in the inner-complex compounds. While the greatest part of the stability of these compounds probably arises from the presence of the 2 chelate rings involving the nickel, 2 carbon and 2 nitrogen atoms, it is feasible that additional stability results from the 2 chelate rings which include the proton.

Willis and Mellor (101) have found that at least 1 nickel(II) vic-dioxime inner-complex compound exhibits paramagnetism when dissolved in pyridine. This investigation should be extended to include more inner-complex compounds and, also, other amines as solvents. The magnetic data compared with infrared spectral data obtained on the same solutions might indicate whether the apparent alteration of structural configuration is aided by a weakening of the O-H-O bond caused by interactions between the nitrogen of the pyridine and the proton.

Magnetic studies of the "inner-complex anion salts" described by Feigl and Suter (25) and Thilo and Friedrich (78) would aid in determining whether the planar configuration is retained upon removing the proton from the O-H-O bond.

Magnetic moment data on nickel(II) complexes formed with the O-monomethyl-vic-dioximes would be of value in establishing the atomic configuration of these molecules and, perhaps, in obtaining additional knowledge of the importance of the oxime hydrogens. Possible steric hindrance arising from the presence of the methoxy groups would have to be considered, however.

V. LITERATURE CITED

1. Badger, R. M., J. Chem. Phys., 8, 288-289 (1940).
2. Banks, C. V. "The synthesis and use of cyclohexanedionedioxime as an analytical reagent." Unpublished M.S. Thesis. Ames, Iowa, Iowa State College Library. 1944.
3. Barker, M. F., Chem. News, 130, 99-100 (1925).
4. Barnes, R. B., and Gore, R. C., Anal. Chem., 21, 7-12 (1949).
5. Barnes, R. B., Gore, R. C., Liddel, U., Williams, V. Z. "Infrared spectroscopy, industrial applications and bibliography," p. 16-18. New York, Reinhold Publishing Corp. 1944.
6. Brady, O. L., and Muers, M. M., J. Chem. Soc., 1930, 1599-1603.
7. Buswell, A. M., Dietz, V., and Rodebush, W. H., J. Chem. Phys., 5, 84 (1937).
8. Buswell, A. M., Rodebush, W. H., and Roy, M. F., J. Am. Chem. Soc., 60, 2444-2449 (1938).
9. Butts, P. G., Gahler, A. R., and Mellon, M. G., Sewage and Ind. Wastes, 22, 1543-1562 (1950).
10. Cambi, L., and Szego, L., Ber., 64, 2591-2598 (1931).
11. Cavell, H. J., and Sugden, S., J. Chem. Soc., 1935, 621-624.
12. Chemical Abstracts, "Miscellaneous chemical prefixes," 39, 5952-5955 (1945).
13. Crane, E. J., Ind. Eng. Chem., News Ed., 13, 200-201 (1935).
14. Davies, M., J. Chem. Phys., 15, 739-741 (1947).
15. Dieckmann, W., Ber., 27, 965-966 (1894).
16. Dieckmann, W., Ber., 30, 1470-1473 (1897).

17. Diehl, H. "The applications of the dioximes to analytical chemistry." Columbus, Ohio, The G. Frederick Smith Chemical Co. 1940.
18. Diehl, H., Chem. Rev., 21, 39-111 (1937).
19. Diehl, H., Henn, J., and Goodwine, W. C., Chemist-Analyst, 35, 76-77 (1946).
20. Dwyer, F. P., and Mellor, D. P., J. Am. Chem. Soc., 57, 605-607 (1935).
21. Feigl, F., Anal. Chem., 21, 1298-1313 (1949).
22. Feigl, F., Ber., 57, 758-761 (1924).
23. Feigl, F., Ind. Eng. Chem., Anal. Ed., 8, 401-410 (1936).
24. Feigl, F. "Qualitative Analyse mit Hilfe von Tüpfelreaktionen," p. 73. Leipzig, Akademische Verlagsgesellschaft. 1931.
25. Feigl, F., and Suter, H. A., J. Chem. Soc., 1948, 378-381.
26. Feinstein, H. I., Anal. Chem., 22, 723-724 (1950).
27. Ferguson, R. C. "Spectrophotometric determination of nickel with vic-dioximes." Unpublished M.S. Thesis. Ames, Iowa, Iowa State College Library. 1950.
28. Ferguson, R. C., and Banks, C. V., Anal. Chem., 23, 448-453 (1951).
29. Ferguson, R. C., and Banks, C. V., Anal. Chem., (Accepted for publication, 1951).
30. Fernelius, W. C., Larsen, E. M., Marchi, L. E., and Rollinson, C. L., Chem. Eng. News, 26, 520-523 (1948).
31. Geissman, T. A., and Schlatter, M. J., J. Org. Chem., 11, 771-772 (1946).
32. Glasstone, S., "Text-book of physical chemistry," p. 569. New York, D. Van Nostrand Company, Inc. 1940.



33. Godchot, M., and Cauquil, G., Compt. rend., 202, 326-328 (1936).
34. Gore, R. C., Anal. Chem., 22, 7-11 (1950).
35. Gore, R. C., Anal. Chem., 23, 7-12 (1951).
36. Griffing, M., and Mellon, M. G., Anal. Chem., 19, 1017-1020 (1947).
37. Hach, C. C., Banks, C. V., and Diehl, H., Org. Syntheses, (Submitted for publication).
38. Hillebrand, W. F., and Lundell, G. E. F., "Applied inorganic analysis," p. 40. New York, John Wiley and Sons, Inc. 1929.
39. Jaeger, F. M., and Bijkerk, L., Proc. Acad. Sci. Amsterdam, 40, 12-23 (1937).
40. Jaeger, F. M., and van Dijk, J. A., Proc. Acad. Sci. Amsterdam, 39, 384-393 (1936).
41. Janes, R. B., J. Am. Chem. Soc., 57, 471-473 (1935).
42. Johnson, W. C., and Simmons, M., Analyst, 71, 554-556 (1946).
43. Kasey, J. B., Chemist-Analyst, 18, No. 1, 8 (1929).
44. Ketelaar, J. A. A., Rec. trav. chim., 60, 523-555 (1941).
45. Klemm, V. W., Jacobi, H., and Tilk, W., Z. anorg. u. allgem. Chem., 201, 1-23 (1931).
46. Kohler, E. P., Tishler, M., Potter, H., and Thompson, H. T., J. Am. Chem. Soc., 61, 1057-1061 (1939).
47. Kuras, M., Collection Czechoslov. Chem. Commun., 12, 198-203 (1947).
48. Kuras, M., Mikrochemie ver. Mikrochim. Acta, 32, 192-194 (1944).
49. Lundell, G. E. F., Hoffman, J. I., and Bright, H. A., "Chemical analysis of iron and steel," p. 32, 281. New York, John Wiley and Sons, Inc. 1931.

50. McAlpine, R. K., and Soule, B. A., "Qualitative chemical analysis," p. 466. New York, D. Van Nostrand Co., Inc. 1933.
51. Mathews, J., Jr., and Diehl, H., Iowa State Coll. J. Sci., 23, 279-287 (1949).
52. Meerwein, H., German Patent 579,309. Abstracted in Chem. Zentr., II, 1758 (1933).
53. Mellor, D. P., and Craig, D. P., J. Proc. Roy. Soc. N. S. Wales, 74, 475-494 (1940).
54. Milone, M., Atti X<sup>o</sup> Congr. intern. chim., 2, 346-352 (1938).
55. Milone, M., and Tappi, G., Atti accad. sci. Torino, Classe sci. fis., mat. nat., 75, 445-453 (1940).
56. Patterson, A. M., J. Am. Chem. Soc., 55, 3905-3925 (1933).
57. Pauling, L. "The nature of the chemical bond." Ithaca, New York, Cornell University Press. 1945.
58. Peltier, S., Duval, T., and Duval, C., Anal. Chim. Acta, 2, 301-306 (1948).
59. Peshkova, V. M., Vedernikova, M. I., and Gontaeva, N. I., Zhur. Anal. Khim., 3, 366-372 (1948).
60. Pfeiffer, P., Ber., 63, 1811-1816 (1930).
61. Pfeiffer, P., and Richarz, J., Ber., 61, 103-107 (1928).
62. Prelog, V., Frenkiel, L., Kobelt, M., and Barman, P., Helv. Chim. Acta, 30, 1741-1749 (1947).
63. Price, W. C., Roy. Inst. Chem., Lectures, Monographs and Repts. 1950, No. 1, 14-20.
64. Raithel, E. E., Chemist-Analyst, 35, 35-38 (1946).
65. Randall, H. M., Fowler, R. G., Fuson, N., and Dangle, J. R. "Infrared determinations of organic structures." New York, D. Van Nostrand Company, Inc. 1949.
66. Rauh, E. G., Smith, G. F., Banks, C. V., and Diehl, H., J. Org. Chem., 10, 199-204 (1945).

67. Reed, S. A., and Banks, C. V., Proc. Iowa Acad. Sci., 55, 267-275 (1948).
68. Riley, H. A., and Gray, A. R., Org. Syntheses, Coll. Vol. II, 509-511 (1943).
69. Riley, H. L., Morley, J. F., and Friend, N. A. C., J. Chem. Soc., 1932, 1875-1883.
70. Rollet, A. P., Compt. rend., 183, 212-213 (1926).
71. Rundle, R. E., and Godycki, L. E., Private communication, Department of Chemistry, Iowa State College.
72. Ruzicka, L., Brugger, W., Pfeiffer, M., Schinz, H., and Stoll, M., Helv. Chim. Acta, 9, 499-520 (1926).
73. Semon, W. L., and Damerell, V. R., Org. Syntheses, Coll. Vol. II, 204-208 (1943).
74. Soule, B. A., J. Am. Chem. Soc., 47, 981-988 (1925).
75. Stoll, M., and Hulstkamp, J., Helv. Chim. Acta, 30, 1815-1821 (1947).
76. Stoll, M., and Rouvé, A., Helv. Chim. Acta, 30, 1822-1836 (1947).
77. Sugden, S., J. Chem. Soc., 1932, 246-250.
78. Thilo, E., and Friedrich, K., Ber., 62, 2990-3000 (1929).
79. Thorpe, J. F., and Kon, G. A. R., Org. Syntheses, Coll. Vol. I., 192-194 (1941).
80. Tokura, N., and Oda, R., Bull. Inst. Phys. Chem. Research (Tokyo), 22, 844-849 (1943).
81. Treadwell, F. P., and Hall, W. T. "Analytical chemistry," Vol. II, p. 141. New York, John Wiley and Sons. 1942.
82. Treibs, A., and Dinelli, D., Ann., 517, 152-169 (1935).
83. Tschugaeff, L. A., J. Chem. Soc., 105, 2187-2193 (1914).
84. Tschugaeff, L., Z. anorg. Chem., 46, 144-169 (1905).
85. Urion, E., Compt. rend., 192, 1662-1664 (1931).

86. Vander Haar, R. W., Voter, R. C., and Banks, C. V., J. Org. Chem., 14, 836-838 (1949).
87. Vène, J., Bull. soc. chim. France, 12, 506-516 (1945).
88. Vogel, A. I. "A textbook of practical organic chemistry including qualitative organic analysis," p. 182. London, Longmans, Green and Co. 1948.
89. Voter, R. C., and Banks, C. V., Anal. Chem., 21, 1320-1323 (1949).
90. Voter, R. C., Banks, C. V., and Diehl, H., Anal. Chem., 20, 458-460 (1948).
91. Voter, R. C., Banks, C. V., and Diehl, H., Anal. Chem., 20, 652-654 (1948).
92. Wagner, E. C., J. Chem. Ed., 10, 113-117 (1933).
93. Wallach, O., Nachr. Ges. Wiss. Göttingen. Math. physik Klasse, 1923, 85-88.
94. Wallach, O., and Weissenborn, A., Ann. 437, 148-186 (1924).
95. Weiss, M., and Appel, M., J. Am. Chem. Soc., 70, 3666-3667 (1948).
96. Welcher, F. J. "Organic analytical reagents," Vol. III, p. 224-251. New York, D. Van Nostrand Co., Inc. 1947.
97. Wenger, P. and Duckert, R., Helv. Chim. Acta, 24, 889-899 (1941).
98. Wenger, P. E., Monnier, D., and Rusconi, Y., Anal. Chim. Acta, 1, 190-200 (1947).
99. Westrum, E. F., Jr., and Pitzer, K. S., J. Am. Chem. Soc., 71, 1940-1949 (1949).
100. Willard, H. H., and Furman, N. H. "Elementary quantitative analysis," p. 446. New York, D. Van Nostrand Co., Inc. 1941.
101. Willis, J. B., and Mellor, D. P., J. Am. Chem. Soc., 69, 1237-1240 (1947).

## VI. ACKNOWLEDGMENTS

This opportunity is taken to express gratitude for the suggestions and encouragement offered by Professor C. V. Banks throughout the course of this research. His keen interest in this work is sincerely appreciated.

Thanks are also due to R. C. Ferguson, who assisted in the micro-determinations, to Professor R. E. Rundle and L. E. Godycki for the information they have supplied concerning the results of their X-ray study of the structure of 1,2-bis(2,3-butanedionedioximo-N,N')nickel(II), to R. W. Vander Haar for his work on the synthesis of 1,2-cycloheptanedionedioxime and to J. L. Pflasterer for performing the micro-Dumas analyses.

In connection with the infrared spectroscopic studies, gratitude is expressed to Professor V. A. Fassel and Professor H. Shull for their advice and to P. W. Kehres and M. Margoshes for operating the Baird spectrophotometer.

Acknowledgment is made to the Ames Laboratory of the Atomic Energy Commission for underwriting the expenses for this investigation, and for providing the necessary facilities for the conduct of the research.